

INSTRUCTION MANUAL

Orion® SteadyPix™ Deluxe Camera Mount #5338



 **ORION**®
TELESCOPES & BINOCULARS
Providing Exceptional Consumer Optical Products Since 1975

Customer Support (800) 676-1343

E-mail: support@telescope.com

Corporate Offices (831) 763-7000

89 Hangar Way, Watsonville, CA 95076

www.OrionTelescopes.com

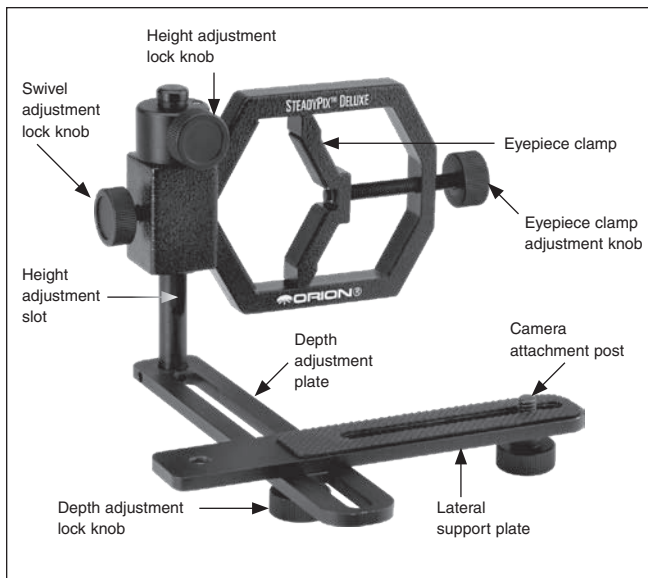

Figure 1. The SteadyPix Deluxe assembled and ready to use.

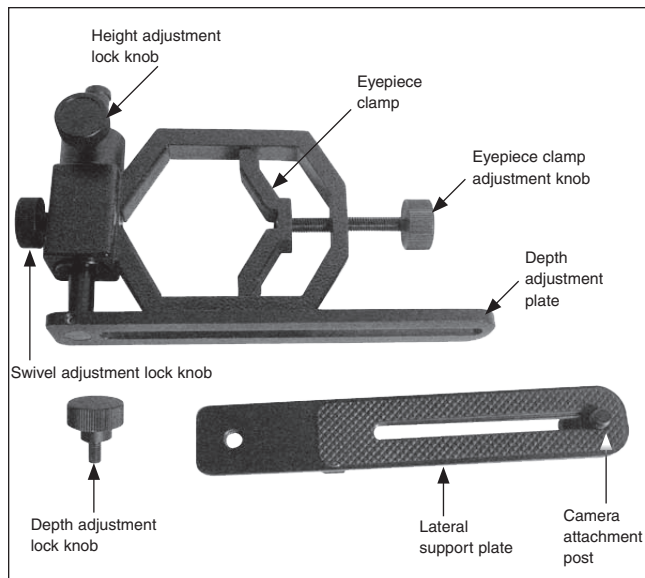

Figure 2. The SteadyPix Deluxe individual component parts.

Welcome to the exciting world of astro-imaging. With the Orion SteadyPix Deluxe, you can shoot your own pictures of celestial objects with just a telescope and camera. The Orion SteadyPix Deluxe is designed for use with point-and-shoot cameras, as well as traditional SLR (single-lens reflex) and DSLR cameras with interchangeable lenses. By using the Orion SteadyPix Deluxe, you won't need all the difficult set-up and extra equipment normally associated with astro-imaging.

1. Parts List

Figure 1 shows the SteadyPix Deluxe assembled and ready to use. Figure 2 shows the parts of your SteadyPix Deluxe as they arrive. Please refer to these photographs to identify the various parts when assembling and using the SteadyPix Deluxe.

- 1 Depth Adjustment Plate with eyepiece clamp and knobs.
- 1 Lateral Support Plate with ¼"-20 camera attachment post.
- 1 Depth Adjustment Lock Knob.

2. Assembling the SteadyPix Deluxe

1. Loosen the Height adjustment lock knob and rotate the eyepiece clamp assembly so that it is perpendicular to the Depth adjustment plate. Position the lock knob so that it is aligned with the slot in the height adjustment shaft and retighten the lock knob (Figure 1).

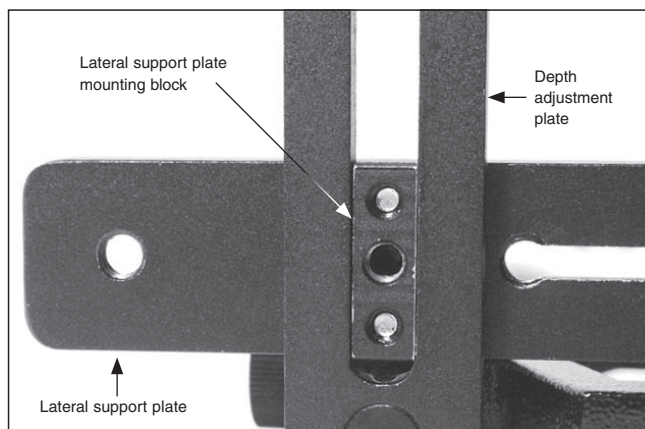

Figure 3. Mount the Lateral support plate into the Depth adjustment plate by placing the mounting block in the slot.

2. Attach the Lateral support plate to the Depth adjustment plate (Figure 2). Align the block located on the underside of the Lateral support plate in the slot that runs along the length of the depth adjustment plate (Figure 3) and secure it in place by tightening the depth adjustment lock knob.

3. About Afocal Photography

The SteadyPix Deluxe lets you couple almost any camera to almost any telescope to do afocal photography. In the afocal method, the camera lens is aimed into the telescope eyepiece. SteadyPix Deluxe is not designed for prime-focus photography, in which the telescope takes the place of the camera's own lens (which is removed).

While it is possible to take pictures by holding the camera up to the eyepiece by hand, small movements of the cam-

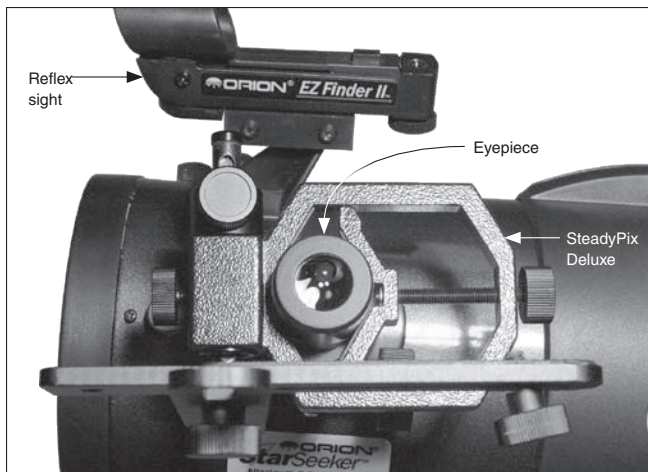

Figure 4. The SteadyPix Deluxe mounted to an eyepiece in a reflector telescope.

era make it difficult to maintain perfect focus and to keep the image centered on the camera's film frame. SteadyPix Deluxe eliminates those problems by locking the camera lens in position relative to the eyepiece. Such coupling also allows the camera to move in synchrony with the eyepiece if the telescope is motor driven.

To get the best pictures with the SteadyPix Deluxe, we recommend using an eyepiece with a long (around 20mm) eye relief. The Orion Epic ED series, for example, has very long eye relief. Long eye relief will allow the camera to see the whole field of view in the eyepiece. Some eyepieces, especially high-power designs, may not have enough eye relief to project the entire field of view into the camera lens, that is, even when the camera lens is right up against the eyepiece, the views will still be constricted.

4. Using the SteadyPix Deluxe

To set up and use the SteadyPix Deluxe:

1. On the underside of most cameras you will find a threaded hole that will accept the SteadyPix Deluxe's Camera attachment post. Attach the camera by inserting the post into the threaded hole of your camera. Certain inexpensive cameras may not have this threaded socket and therefore will not be compatible with the SteadyPix Deluxe.
2. Begin by setting up the camera as far away from the eyepiece clamp as possible.

Note: some cameras have lenses that expand outward beyond the camera body when powered on. Take caution that you have allowed sufficient clearance before aligning the camera with the eyepiece.

3. Locate the object you wish to photograph in your telescope. Before attaching the SteadyPix Deluxe, focus the image in the telescope's eyepiece using the



Figure 5. A camera attached to the SteadyPix Deluxe mounted on a reflector telescope and ready to use.

telescope's focuser. Make sure the telescope mount is locked down once you have centered your target. Also confirm that the eyepiece is securely locked down in the telescope focuser.

4. Loosen the eyepiece clamp adjustment knob until the clamp is wide enough to fit around the body of the eyepiece. Then place the clamp over the eyepiece and tighten the eyepiece clamp adjustment knob until the SteadyPix Deluxe is secure on the telescope.
5. Loosen the 1/4"-20 camera adjustment post, then slide the camera along the depth adjustment plate towards the eyepiece. Loosen the shaft knob just a bit and adjust the depth adjustment plate so that the eyepiece will line up with the camera lens. Do this by sliding the camera along the lateral adjustment plate to match the orientation of the camera lens with the eye lens of the eyepiece. The camera lens and eyepiece will likely need to get quite close to each other to work properly, but make sure they do not touch or else damage to the eyepiece or camera lens may occur.
6. Look at the camera's viewscreen or viewfinder to see if the object is there. If not, some finer adjustments may need to be made. Try bringing the camera lens closer to the eyepiece, or adjust the camera support plate by loosening the shaft knob and moving it left or right and up or down. Keep making minor adjustments until the image from the eyepiece takes up as much space in the viewscreen or viewfinder as it possibly can. Be sure to tighten the 1/4"-20 camera attachment post when you are ready.
7. Focus the camera, and shoot the picture.

Some telescopes mounts, such as Dobsonian mounts, may move very easily if any pressure is put against the eyepiece. The act of placing the SteadyPix Deluxe over the eyepiece and readying it for shooting may cause the telescope to move off of its target. You may find it easier to attach the eyepiece and camera to the SteadyPix Deluxe in advance, and then find the object you wish to photograph with a separate eye-

piece with similar characteristics. Then replace that eyepiece with the SteadyPix Deluxe, camera, and eyepiece assembly you have prepared in advance.

You may find it handy to use the camera's timer to take your picture, as this will result in minimal disturbances to the camera or telescope when snapping the photo. The movement of pressing the shutter button may be enough motion to affect image quality, or even lose the picture.

5. What to Photograph with the SteadyPix Deluxe

Now that you have assembled the SteadyPix Deluxe, the only question remaining is "What do I want to photograph?" We have a few suggestions for you:

Terrestrial Photography

With literally millions of objects to photograph on earth, there are only a few hints we can give for using the SteadyPix Deluxe for terrestrial photography. One is to consider using a telescope with an Alt/Az (short for altitude/azimuth) mount on a sturdy tripod. An Alt/Az mount will allow simple up/down, left/right motions of the telescope so that you can easily adjust and aim the camera. Equatorial mounts (mounts designed to track the movement of stars in the sky) are not recommended, as they will be needlessly heavy due to the counterweight, and their ability to track celestial objects is of no use when photographing an object like a bird's nest. In fact it will likely get in the way. Dobsonian mounts will also have trouble with terrestrial photography since aiming a Dobsonian mounted telescope at something close to the horizon (where most terrestrial photography takes place) will mean it has to be very low to the ground and hard to use.

Remember that objects viewed through certain types of telescopes can be oriented backwards, upside-down, or both.

The Moon

The Moon is one of the easiest and most interesting targets to photograph. With its rocky, cratered surface there is a wealth of detail to be photographed with your camera and SteadyPix Deluxe. The Moon is a very large target, so at higher magnifications you will only get a part of the surface in each picture. Use eyepieces that provide low powers (50x and below should work with most telescopes) if you wish to have the entire surface of the Moon in your field of view.

Photographing the full moon can be difficult since sunlight is falling directly on lunar surface and will mean there are very few shadows, so details will be harder to see. Photographing the Moon when it is in one of its partial phases is preferable, when the angle of the sun provides many detailed shadows on its surface. You might also want to use an optional Moon

filter that threads onto the bottom of the eyepiece to bring out more subtle features on the lunar surface, even during a full moon.

The Bright Planets

Next to the Sun and the Moon, the planets Mars, Venus, Jupiter and Saturn are the brightest objects in the sky and make excellent targets for photography. Keep in mind that the planets don't stay still like the stars, so to find them you should refer to Sky Calendar at our website (OrionTelescopes.com), or to charts published monthly in Astronomy, Sky & Telescope, or other astronomy magazines.

To get the right amount of detail on the planets, eyepieces that give high powers (at least 75x or more) should be used when using the SteadyPix Deluxe. Low powers will make it easier to find the planets, but they will not bring out any significant details on the planets to make them worth photographing. High powers must be used to get images of the famous details of the planets, such as the rings of Saturn or bands on Jupiter's surface.

You might also consider using colored planetary filters that thread onto the bottom of the eyepiece (just like the Moon filter). These colored filters bring out subtle details of the planets by filtering out various colors that reduce detail. Orion has several sets of colored filters available. Visit our website, telescope.com, for more information on colored planetary filters

Deep-Sky Objects

Since deep-sky objects are very faint, use only digital cameras to photograph them when using the SteadyPix Deluxe. Film cameras require too much exposure time to get good results. A few bright objects can be photographed effectively using your SteadyPix Deluxe (such as the Orion Nebula). Other deep-sky objects may also be photographed for interesting pictures. Try experimenting with different deep-sky objects to see what kind of results you can obtain.

One-Year Limited Warranty

This Orion SteadyPix Deluxe is warranted against defects in materials or workmanship for a period of one year from the date of purchase. This warranty is for the benefit of the original retail purchaser only. During this warranty period Orion Telescopes & Binoculars will repair or replace, at Orion's option, any warranted instrument that proves to be defective, provided it is returned postage paid to: Orion Warranty Repair, 89 Hangar Way, Watsonville, CA 95076. If the product is not registered, proof of purchase (such as a copy of the original invoice) is required.

This warranty does not apply if, in Orion's judgment, the instrument has been abused, mishandled, or modified, nor does it apply to normal wear and tear. This warranty gives you specific legal rights, and you may also have other rights, which vary from state to state. For further warranty service information, contact: Customer Service Department, Orion Telescopes & Binoculars, 89 Hangar Way, Watsonville, CA 95076; (800) 676-1343.



89 Hangar Way, Watsonville, CA 95076

Customer Support Help Line (800) 676-1343 • Day or Evening