

INSTRUCTION MANUAL

Orion[®] ShortTube[™] 80-T

80mm Rich-Field Refracting Telescope

#9946



 **ORION[®]**
TELESCOPES & BINOCULARS
Providing Exceptional Consumer Optical Products Since 1975

Customer Support (800) 676-1343
E-mail: support@telescope.com

Corporate Offices (831) 763-7000
89 Hangar Way, Watsonville, CA 95076

Welcome to a new world of adventure! Your Orion ShortTube 80-T is a fine-quality instrument designed for both daytime terrestrial viewing and nighttime stargazing. Compact, portable, and easy to use, this versatile scope will provide many hours of enjoyment for the whole family.

These instructions will help you set up and properly use and care for your telescope. Please read them over thoroughly before getting started.

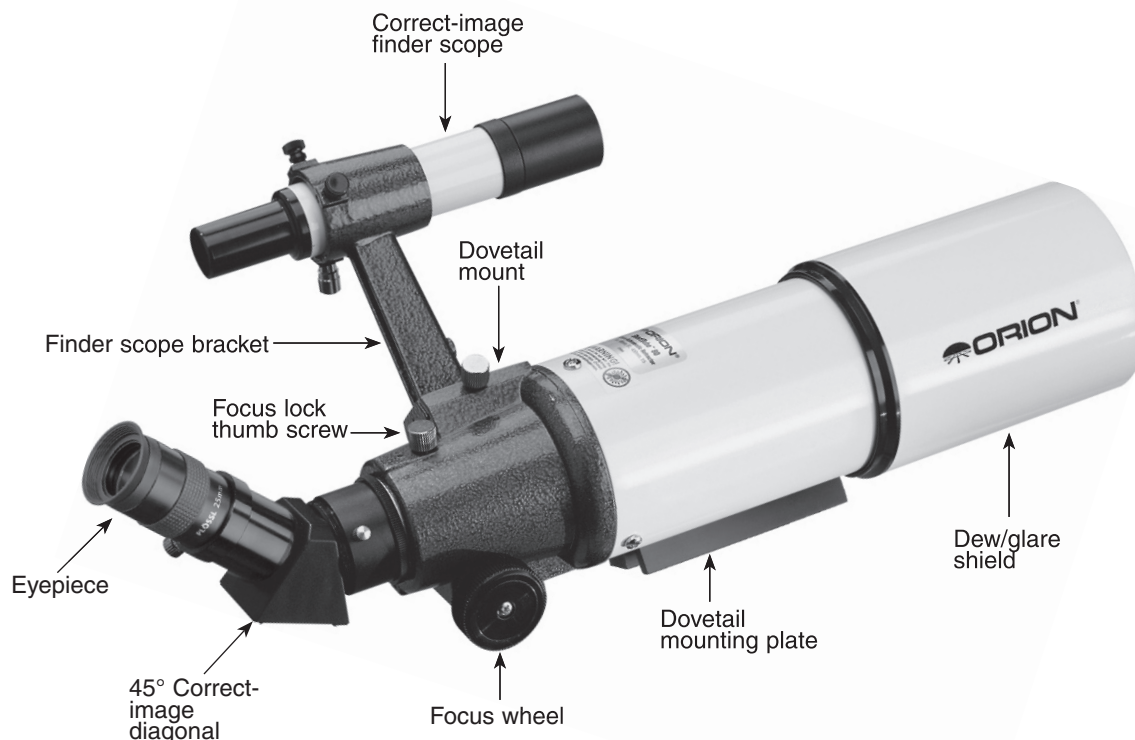

Figure 1. The ShortTube 80-T refractor

WARNING: Never look at the sun with your telescope (or even with just your eyes) without a professionally made solar filter. Permanent eye damage or blindness could result. Young children should use this telescope only with adult supervision.

Avoid using the type of solar filter that screws into an eyepiece. They are susceptible to cracking under the intense heat that builds up near the focus point, and could cause severe retinal damage. Use only the type of solar filter that covers the front of the telescope. Be sure also to cover the front of the finder scope with aluminum foil or another opaque material to prevent physical damage to the internal components of the scope itself as well as to your eyes.

Parts List

Qty.	Description
1	Optical tube assembly
1	25mm Sirius Plössl 1.25" eyepiece (16x)
1	10mm Sirius Plössl 1.25" eyepiece (40x)
1	45° correct-image diagonal, 1.25"
1	6x26 correct-image finder scope
1	Soft carry case
1	Finder scope bracket with O-ring
1	Objective lens cap

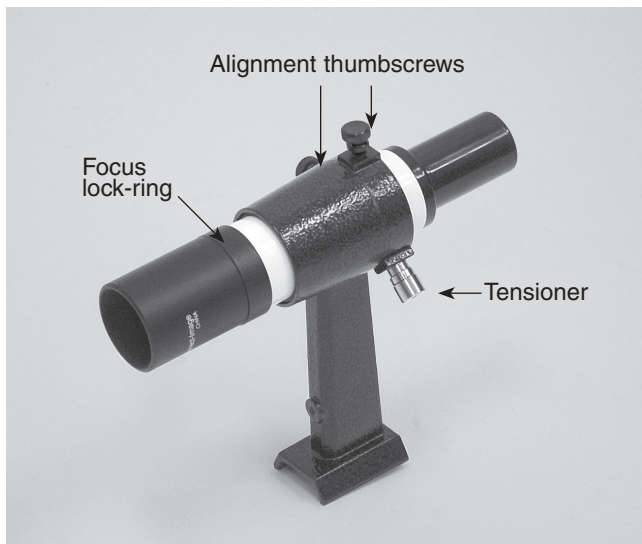

Figure 2a. The 6x26 correct-image finder scope and bracket.

Getting Started

The ShortTube 80-T comes nearly fully assembled from the factory. The telescope's optics have been installed and collimated, so you should not have to make any adjustments to them. Open the box and inspect the contents to make sure all of the items in the parts list are present.

Please keep the original shipping box. In the unlikely event you should need to ship the telescope back to Orion for warranty repair service, you should use the original packaging. The box also makes a very good container for storing the telescope when it is not in use.

Installing the Finder Scope

To place the finder scope in the finder scope bracket, first unthread the two black nylon thumbscrews until the screw ends are flush with the inside diameter of the bracket. Place the O-ring that comes on the base of the bracket over the body of the finder scope until it seats into the slot on the middle of the finder scope. Slide the eyepiece end (narrow end) of the finder scope into the end of the bracket's cylinder opposite the adjustment screws while pulling the chrome, spring-loaded tensioner on the bracket with your fingers (Figure 2b.) Push the finder scope through the bracket until the O-ring seats just inside the front opening of the bracket's cylinder. Now, release the tensioner and tighten the two black nylon screws a couple of turns each to secure the finder scope in place. Secure the bracket to the dovetail mount on the optical tube with the knurled thumbscrew provided.

Installing the Diagonal and Eyepiece

Insert the 45° diagonal into the focuser drawtube and secure it with the knurled thumbscrew on the drawtube. Then insert the 25mm Plössl eyepiece into the diagonal and secure it in place with the thumbscrews on the diagonal. (Always loosen the thumbscrews before rotating or removing the diagonal or an eyepiece.)



Figure 2b. Inserting the finder scope into the finder scope bracket.

Mounting the Telescope

The ShortTube 80-T can be mounted on any standard camera tripod that has a 1/4"-20 stud. The stud threads into one of the threaded holes on the bottom of the dovetail mounting plate attached to the underside of the telescope optical tube.

You can also easily mount the telescope on altazimuth telescope mounts like the Orion VersaGo. The dovetail mounting plate on the bottom of the ShortTube 80-T connects to the VersaGo mount's dovetail holder. The dovetail holder has two knobs to hold the dovetail mounting plate securely. Loosen these two knobs accordingly and while grasping the telescope firmly, place the dovetail mounting plate into the VersaGo's dovetail holder. Tighten the two knobs to secure the telescope.

Alternatively, the telescope can be attached to any Orion equatorial mount equipped with a dovetail holder. Follow the directions above to couple the mounting plate to the equatorial mount's dovetail holder.

An equatorial mount is desirable for astronomical viewing because it allows easy manual tracking of celestial objects as the Earth rotates. Also, the setting circles on the mount enable you to locate objects by their celestial coordinates (right ascension and declination), which can be found in many observing books and star atlases.

Focusing

The ShortTube 80-T is equipped with a precision rack-and-pinion focuser. When you first look in the eyepiece, the image you see may be fuzzy, or out of focus. If so, gently turn one of the focusing wheels with your fingers until the image becomes sharp. You will have to readjust the focus when aiming at subjects of varying distances, or after changing eyepieces. Make sure the focus thumbscrew is loosened before focusing. After focusing, you can tighten it to lock the telescope's focus into place.

Do You Wear Eyeglasses?

If you wear eyeglasses, you may be able to keep them on while you observe, if your eyepieces have enough “eye relief” to allow you to see the whole field of view. You can find out by looking through the eyepiece first with your glasses on and then with them off, and see if the glasses restrict the view to only a portion of the full field. If they do, you can easily observe with your glasses off by just refocusing the telescope the needed amount.

Aligning the Finder Scope

The ShortTube 80-T comes with a 6x26 correct-image achromatic finder scope. (The 6x means six-times magnification, and the 26 indicates a 26mm aperture.) The finder scope makes it easier to locate the subject you want to observe in the telescope, because the finder scope has a much wider field of view. Unlike most finder scopes, images viewed in the correct-image finder scope will appear properly oriented (same as the naked eye), which makes finding objects even easier.

Before you use the finder scope, it must be precisely aligned with the telescope, so they both point to exactly the same spot. Alignment is easiest to do in daylight, rather than at night under the stars. First, insert the lowest-power (25mm) eyepiece into the telescope’s focuser. Then point the telescope at a discrete object such as the top of a telephone pole or a street sign that is at least a quarter-mile away. Move the telescope so the target object appears in the very center of the field of view when you look into the eyepiece.

Now look through the finder scope. Is the object centered in the finder scope’s field of view, i.e., on the crosshairs? If not, hopefully it will be visible somewhere in the field of view, so only fine adjustment of the two black nylon alignment screws will be needed. Otherwise you’ll have to make coarser adjustments to the alignment screws to redirect the aim of the finder scope.

Use the two alignment screws to center the object on the crosshairs of the finder scope. Then look again into the telescope’s eyepiece and see if it is still centered there as well. If it isn’t, repeat the entire process, making sure not to move the telescope while adjusting the alignment of the finder scope.

Finder scopes can come out of alignment during transport of the telescope, so check the alignment before each observing session.

Focusing the Finder Scope

If, when looking through the finder scope, you notice that the images appear somewhat out of focus, you will need to refocus the finder scope for your eyes. First loosen the lock ring located behind the objective lens cell on the body of the finder scope (see Figure 2a). Back the lock ring off by a few turns, for now. Refocus the finder scope on a distant object by threading the objective lens cell in or out of the finder scope body. Precise focusing will be achieved by focusing the finder scope on a bright star. Once the image appears sharp, retighten the lock ring behind the objective lens cell. The finder scope’s focus should not need to be adjusted again.

Terrestrial Viewing

Many people enjoy using their telescope to view objects such as boats, birds and wildlife. The ShortTube 80-T is an excellent instrument for observing during the daylight hours.

For terrestrial applications, we recommend mounting the ShortTube 80-T on an altazimuth-style camera tripod or telescope mount such as the Orion VersaGo, which allow simple vertical (altitude) and horizontal (azimuth) motions.

Astronomical Viewing

The ShortTube 80-T excels for astronomical observation. Its unobstructed 80mm aperture and short 400mm focal length (f/5) provide bright, expansive views of star fields and celestial objects residing within our solar system and beyond.

The ShortTube 80-T can show much more than what is visible on Earth during the day. Once the Sun sets, there are literally thousands of objects in the night sky that can be inspected more closely. For astronomical usage, we recommend a 90° star diagonal instead of the 45° correct-image diagonal that comes with the telescope. The correct-image diagonal is designed for daytime use, and will cause some degradation of image quality when used for astronomy. Also, the viewing angle provided by a 90° star diagonal is more comfortable for looking up. When using a star diagonal, the image in the eyepiece will appear backwards (inverted left-to-right).

For casual stargazing, an altazimuth mount will do the job just fine. But an equatorial mount is designed to make it easier to manually “track” the motion of celestial objects with just one slow-motion cable. Furthermore, with an equatorial mount you can add an optional motor drive to track the stars automatically—a great convenience.

When selecting a location for nighttime stargazing, make it as far away from city lights as possible. Light-polluted skies greatly reduce what can be seen with the telescope. Also, give your eyes at least 20 minutes to dark-adapt to the night sky. You’ll be surprised at how many more stars you will see! Use a red flashlight to see what you’re doing at the telescope, or to read star charts. Red light will not spoil your dark-adapted night vision as readily as white light will.

To find celestial objects with your telescope, you first need to become reasonably familiar with the night sky. Unless you know how to recognize the constellation Orion, for instance, you won’t have much luck locating the Orion Nebula. A simple planisphere, or star wheel, can be a valuable tool for learning the constellations and seeing which ones are visible in the sky on a given night.

A good star chart or atlas can come in handy for helping locate interesting objects among the dizzying multitude of stars overhead. Except for the Moon and the brighter planets, it is pretty time-consuming and frustrating to hunt for objects randomly, without knowing where to look. It is best to have specific targets in mind before you begin looking through the eyepiece.

A. The Moon

The Moon, with its rocky, cratered surface, is one of the easiest and most interesting subjects to observe with your telescope. The myriad craters, rilles, and jagged mountain formations offer endless fascination. The best time to observe the Moon is during a partial phase, that is, when the Moon is not full. During partial phases, shadows cast by crater walls and mountain peaks along the border between the dark and light portions of the lunar disk highlight the surface relief. A full Moon is too bright and devoid of surface shadows to yield a pleasing view. Try using a Moon filter to dim the Moon when it is too bright; it simply threads onto the bottom of the eyepiece.

B. The Sun

You can change your nighttime telescope into a daytime Sun viewer by installing an optional full-aperture solar filter over the front opening of the ShortTube 80-T. The primary attraction is sunspots, which change shape, appearance, and location daily. Sunspots are directly related to magnetic activity in the Sun. Many observers like to make drawings of sunspots to monitor how the Sun is changing from day to day.

Important Note: Do not look at the Sun with any optical instrument without a professionally made solar filter, or permanent eye damage could result. Also, remember to cover or remove the finder scope.

C. The Planets

The planets don't stay put like stars do (planets don't have fixed R.A. and Dec. coordinates), so you will have to refer to Sky Calendar at our website, www.OrionTelescope.com, or to charts published monthly in *Astronomy*, *Sky & Telescope*, or other astronomy references to locate them. Venus, Mars, Jupiter, and Saturn are the brightest objects in the sky after the Sun and the Moon. All four of these planets are not normally visible in the sky at one time, but chances are one or two of them will be.

D. Stars

Stars will appear like twinkling points of light in the telescope. Even the largest telescopes cannot magnify stars to appear as anything more than points of light! You can, however, enjoy the different colors of the stars and locate many pretty double and multiple stars. The famous "Double-Double" in the constellation Lyra and the gorgeous two-color double star Albireo in Cygnus are favorites. Defocusing the image of a star slightly can help bring out its color.

E. Deep-Sky Objects

Under dark skies, you can observe a number of brighter deep-sky objects with your ShortTube 80-T, including gaseous nebulas, open and globular star clusters, and the brighter galaxies. Most deep-sky objects are very faint, so it is important that you find an observing site well away from light pollution. Take plenty of time to let your eyes adjust to the darkness. Don't expect these objects to appear like the photographs you see in books and magazines; most will look like dim gray "ghosts." (Our eyes are not sensitive enough to see color in deep-sky objects except in few of the brightest ones.) But as you become more experienced and

your observing skills improve, you will be able to coax out more and more intricate details.

Calculating Magnification (Power)

It is desirable to have a range of eyepieces of different focal lengths, to allow viewing over a range of magnifications. To calculate the magnification, or power, of a telescope, simply divide the focal length of the telescope by the focal length of the eyepiece:

$$\text{Telescope F.L.} \div \text{Eyepiece F.L.} = \text{Magnification}$$

For example, the ShortTube 80-T, which has a focal length of 400mm, used in combination with the supplied 25mm Sirius Plössl eyepiece, yields a magnification of

$$400 \div 25 = 16x.$$

Every telescope has a useful limit of magnification of about 45x-60x per inch of aperture, which is 140x-180x for the ShortTube 80-T. Claims of higher power by some telescope manufacturers are a misleading advertising gimmick and should be dismissed. Keep in mind that at higher powers, an image will always be dimmer and less sharp (this is a fundamental law of optics). The steadiness of the air (the "seeing") can also limit how much magnification an image can tolerate.

Always start viewing with your lowest-power (longest focal length) eyepiece in the telescope. After you have located and looked at the object with it, you can try switching to a higher-power eyepiece, like the supplied 10mm Sirius Plössl eyepiece, to ferret out more detail. If the image you see is not crisp and steady, reduce the magnification by switching to a longer-focal-length eyepiece. As a general rule, a small but well-resolved image will show more detail and provide a more enjoyable view than a dim and fuzzy, overmagnified image.

Photography with the ShortTube 80-T

With an optional camera adapter, the ShortTube 80-T becomes a 400mm f/5 telephoto lens for a single-lens reflex camera. For long-distance terrestrial or astronomical photography, you need only a T-ring for your particular camera model. The T-ring attaches to your particular camera model and threads onto the ShortTube's focuser drawtube, coupling the camera body to the telescope (Figure 3).

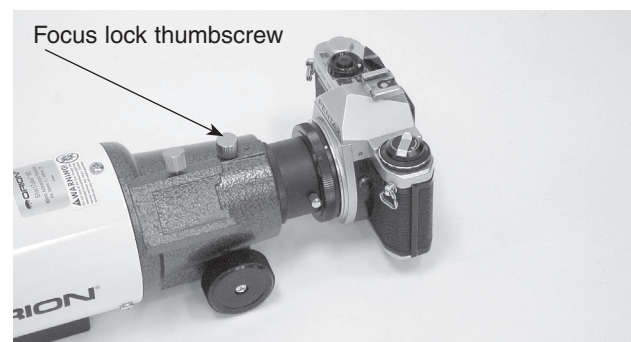

Figure 3. The ShortTube 80-T with 35mm SLR camera attached.

For closer-range (less than 1/4-mile) terrestrial photography, you need both a T-ring for your camera and a T-adaptor (#5264), which provides the extra focus travel needed. Remove the nosepiece from the camera adapter; the body of the adapter will not be needed here. Connect the T-ring to your camera body (remove any camera lenses first), and connect the nosepiece of the camera adapter to the T-ring. Now, insert the entire assembly into the focuser's drawtube (remove the eyepiece and diagonal), and secure with the thumbscrew on the drawtube. Be sure to tighten the thumbscrew, or your camera could fall to the ground!

Use the camera's viewfinder to frame the picture. Use the telescope's focuser to focus the image. Tighten the focus lock thumbscrew on the telescope's focuser to make sure the camera does not slip out of focus.

You may want to consider using a remote shutter release instead of the shutter release on the camera. Touching the camera can vibrate the system and blur the resulting photographic image. Also, be sure to use a solid tripod.

Care & Maintenance

Give your telescope reasonable care and it will last a lifetime. Do not leave the telescope outside except when using it. The optical tube is aluminum and has a smooth painted surface that should resist scratches and smudges. If a scratch does appear on the tube, it will not harm the telescope. If you wish, you can apply some white auto touch-up paint to the scratch. Smudges on the tube can be wiped off with standard household cleaning fluid

Any quality optical lens tissue and cleaning fluid specifically designed for multi-coated optics can be used to clean the telescope's objective lens as well as the lenses of the eyepieces and finder scope. Never use regular glass cleaner or cleaning fluid designed for eyeglasses. Before cleaning with fluid and tissue, however, blow any loose particles off the lens with a blower bulb or compressed air, or lightly brush the lens with a soft camel hair brush. Apply some cleaning fluid to a tissue, never directly on the optics. Wipe the lens gently in a circular motion, then remove any excess fluid with a fresh lens tissue. Oily fingerprints and smudges may be removed using this method. Use caution; rubbing too hard may scratch the lens! On larger lenses, clean only a small area at a time, using a fresh lens tissue on each area. Never reuse tissues.

The ShortTube 80-T includes a soft-sided carrying case. The carrying case will hold the ShortTube 80-T safely during transport and doubles as a convenient storage spot when the telescope is not in use. You will need to remove accessories such as the eyepiece, diagonal, and finder scope in order to place the telescope into the case. The finder scope can be stored on top of the padded velcro flap that covers the telescope. The other accessories can be stored in the exterior pockets of the carrying case for easy transport.

Specifications

Objective lens:	Achromatic doublet, air-spaced
Objective lens coatings:	Fully multi-coated
Aperture:	80mm
Focal length:	400mm
Focal ratio:	f/5
Focuser:	Rack-and-pinion, 1.25", accepts camera T-ring
Optical tube length:	15"
Weight of optical tube assembly:	3lbs. 7oz.
Mounting provision:	Dovetail mounting plate with 1/4"-20 threaded holes
Finder scope:	6x Magnification, 26mm aperture, correct-image, achromatic, crosshairs
Eyepieces:	25mm (16x) and 10mm (40x) Sirius Plössl, 1.25" barrel diameter, fully coated, threaded for Orion filters
Diagonal:	45° correct-image, 1.25" barrel diameter
Case:	Deluxe soft case with exterior pockets



One-Year Limited Warranty

The Orion ShortTube™ 80-T Refractor is warranted against defects in materials or workmanship for a period of one year from the date of purchase. This warranty is for the benefit of the original retail purchaser only. During this warranty period Orion Telescopes & Binoculars will repair or replace, at Orion's option, any warranted instrument that proves to be defective, provided it is returned postage paid to: Orion Warranty Repair, 89 Hangar Way, Watsonville, CA 95076. Proof of purchase (such as a copy of the original receipt) is required.

This warranty does not apply if, in Orion's judgment, the instrument has been abused, mishandled, or modified, nor does it apply to normal wear and tear. This warranty gives you specific legal rights, and you may also have other rights, which vary from state to state. For further warranty service information, contact: Customer Service Department, Orion Telescopes & Binoculars, 89 Hangar Way, Watsonville, CA 95076; (800) 676-1343.