

INSTRUCTION MANUAL

Orion® Illuminated Polar Scope for Sirius™ Pro AZ/EQ-G Mount #7152



 **ORION**
TELESCOPES & BINOCULARS
Providing Exceptional Consumer Optical Products Since 1975

Customer Support:

www.OrionTelescopes.com/contactus

Corporate Offices:

89 Hangar Way, Watsonville CA 95076 - USA

Copyright © 2015 Orion Telescopes & Binoculars
All Rights Reserved. No part of this product instruction or any of its contents
may be reproduced, copied, modified or adapted, without the prior written
consent of Orion Telescopes & Binoculars.

Before operating the Sirius Pro AZ/EQ-G mount in equatorial mode for astrophotography, it must be accurately polar aligned. The SynScan hand controller provides a polar alignment routine to be performed after a 2-Star or 3-Star GoTo alignment. You do not need a polar scope to perform the SynScan-based polar alignment routine. Please refer to the SynScan hand controller manual for detailed instructions.

This polar axis scope provides a convenient alternative to the SynScan-based polar alignment method. Many people prefer a polar scope because of its ease of use and the speed at which polar alignment can be achieved. This polar scope mounts externally rather than inside the housing of the mount as is common with many other polar scopes.

These instructions cover how to install and use the polar scope. Please read them thoroughly before getting started.

1. Set up the Sirius Pro AZ/EQ-G mount (*Refer to the separate instruction manual for that mount.*) It is recommended to load the mount with the telescope and counterweights prior to polar alignment.
2. Loosen the two polar scope attachment knobs already installed on your mount to remove the bubble level (**Figure 1**), then attach the polar scope with the same screws/knobs.
3. Attach the polar scope illuminator to the front of the polar scope (**Figure 2**).

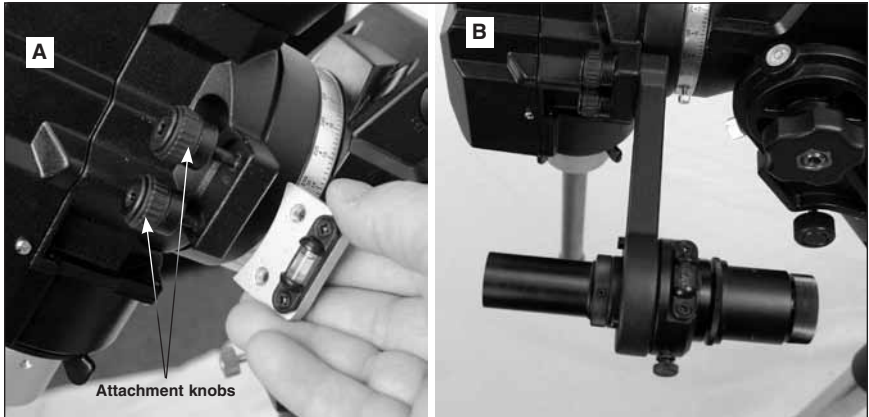

Figure 1. **A)** Loosen the lock knobs on the mount to remove the bubble level. **B)** Then replace it with the polar scope bracket and tighten the two lock knobs.

WARNING: *Never look directly at the Sun with the naked eye or with a telescope – unless you have a proper solar filter installed over the front of the telescope! Otherwise, permanent, irreversible eye damage may result.*



Figure 2. The illuminator fits on the front of the polar scope.

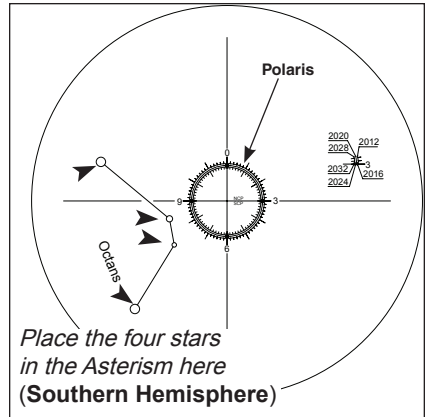

Figure 3. The reticle pattern of the polar scope

4. Point the mount in the direction of the North Celestial Pole (for Northern Hemisphere observing) or South Celestial Pole (for Southern Hemisphere observing). Set the R.A. axis's elevation to the local latitude. (*Refer to Section 3.3 of the Sirius Pro mount manual.*)
5. Rotate the battery cap clockwise to turn on the power of the polar scope illuminator. You may need to rotate the smaller brightness dial in the same direction to see the red LED illuminate.
6. Verify that the polar scope is aligned with the mount's R.A. axis (*Refer to section 3.4 Calibrating the Polar Scope.*)

Once the polar scope is illuminated, when you look into the polar scope you should see the reticle pattern shown in **Figure 3**. If the image appears blurry, rotate the knurled ring of the polar scope's eyepiece to focus.

The reticle allows accurate polar alignment from either hemisphere.

1. **For observing in the Northern Hemisphere:** The circle with fine graduations in the center of the reticle is for polar alignment in the northern hemisphere. Find the star Polaris (the brightest star near the North Celestial Pole, or NCP) in the polar scope; then use the spring loaded elevation adjustment handle and the two azimuth adjustment knobs on the mount (**Figure 4**) to move Polaris to the proper position in that graduated circle (*Refer to the upcoming section "The Orientation of Polaris in Polar Scope"*). Polaris's orbit around the NCP—which is represented by the intersection of the two perpendicular crosshairs—changes gradually. The three central circles in the polar scope reticle are the orbits for the years 2012, 2020, and 2032. Users should refer to these circles and the current year to put Polaris at the proper radius.

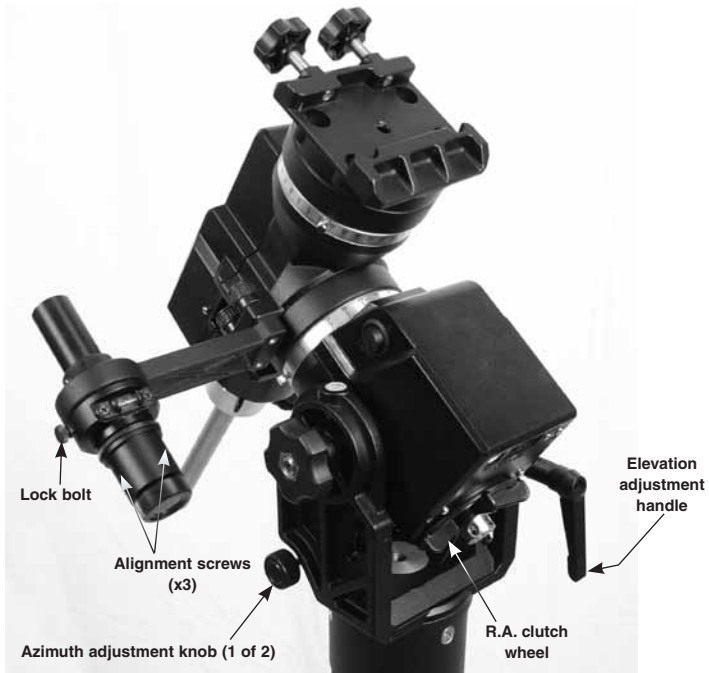

Figure 4. Calibrating the polar scope requires adjusting the mount's manual elevation and azimuth controls.

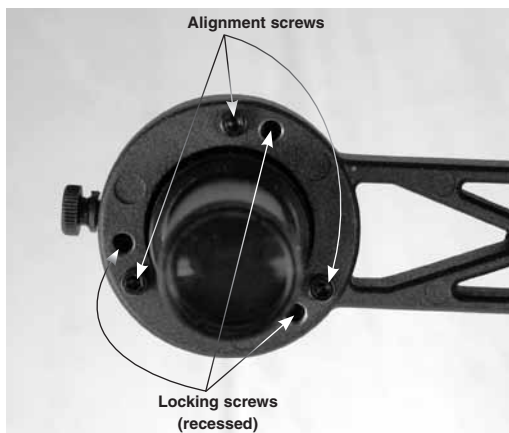

Figure 5. The screws with the raised heads on the front of the polar scope bracket are the alignment screws; the recessed screws are merely locking screws.

-
- 2. For observing in the Southern Hemisphere:** In the polar scope's field of view, locate the four dim stars (~ magnitude 5 - 6) of Octans that conform to the pattern shown on the reticle. Use the spring loaded elevation adjustment handle and the two azimuth adjustment knobs on the mount (**Figure 4**) to move those stars into the four small circles labeled "Octans" on the reticle.

3.3 The Orientation of Polaris

Polaris is not located exactly at the North Celestial Pole; it is offset from it by less than 1 degree. The "Polaris circle" seen in **Figure 3** is a representation of Polaris' orbit around the NCP. When polar aligning the Sirius Pro mount, you'll need to determine where Polaris should be positioned on that circle, relative to the NCP, for the current time and date. You can use either of the following two methods to get the orientation:

1. Locate both Polaris and the star Kochab in the sky; Kochab is in the "pan" of the Little Dipper, while Polaris is at the end of the "handle". The direction from Polaris to Kochab can be used as an approximation of the orientation of Polaris in the polar scope. Put Polaris on the circle on the opposite side of the NCP from where Kochab is located.
2. At the end of the initialization of the SynScan hand control, after entering the proper local longitude, latitude, date, time, and Daylight Saving time, the SynScan hand controller will display the message: "Polaris Position in P.Scope=HH:MM". Imagine the graduated circle in **Figure 3** as a clock's face with 12:00 at the top, with the current time pointing to the "HH:MM". The orientation of the hour hand of the clock represents the orientation of Polaris in the polar scope. Put Polaris in the same orientation on the graduated circle to finish the polar alignment.

Of the two methods above, the method utilizing the SynScan hand controller is the more accurate.

3.4 Calibrating the Polar Scope

The polar scope must be calibrated to ensure accurate polar alignment. That means it has to be precisely aligned with the mount's R.A., or "polar", axis. The following steps outline how to calibrate the polar scope. It's easiest to do during daylight hours.

Step 1 - Align Polar Scope's Optical Axis with the Center of the Reticle

1. Put a distant landmark or object at the center of the reticle in the polar scope's FOV using the azimuth adjustment knobs and the elevation adjustment handle (**Figure 4**).
2. Loosen the polar scope lock bolt.
3. Rotate the polar scope 180 degrees, then re-tighten the lock bolt.
(NOTE: you're rotating the polar scope itself inside its bracket; you're not rotating the R.A. axis of the mount until Step 3)

-
4. If the object is still at the center of the reticle, there is no need for further adjustment.
 5. If the object moved off center, adjust the three alignment screws (**Figure 4**) with a 1.5mm Allen key to move the object HALFWAY back to center. When making the adjustment, loosen one screw by 1/4 turn each time, then tighten the other two screws.
 6. Repeat the above procedure until the object remains at the center when rotating the polar scope 180 degrees.

Step 2 - Align Vertical Line of the Reticle

1. Loosen the attachment knobs in **Figure 1A** and level the polar scope horizontally using the bubble level on the polar scope. Then re-tighten the attachment knobs.
2. Point the polar scope to a distant object that has a vertical reference line.
3. Loosen the locking bolt in **Figure 4**, then rotate the polar scope so the 0–6 line in the reticle is parallel to the vertical reference of the object.
4. Re-tighten the polar scope locking bolt.

Step 3 - Align Polar Scope Optical Axis with Mount's R.A. Axis

1. Put a distant landmark or object in the center of the reticle in the polar scope's FOV with the azimuth adjustment knobs and the elevation adjustment handle (**Figure 4**).
2. Loosen the R.A. clutch wheel and rotate the R.A. axis 180 degrees.
3. If the object is still at the center of the reticle, there is no need for further adjustment.
4. If the object moved off center, adjust the three alignment screws on the front of the polar scope bracket (they have the raised heads) (**Figure 5**) with a 2.5mm Allen key to move the object HALFWAY back to center.

NOTE: *There are three pairs of screws. The three screws with the raised heads are spring-loaded alignment screws. The three recessed screws are simply locking screws. Before making any adjustments, loosen all three locking screws (also with a 2.5mm Allen key) by a couple of turns. When finished with the alignment, you will lightly re-tighten the locking screws to secure the polar scope's alignment (Step 7).*

5. When making the adjustment, loosen one alignment screw 1/4 turn each time, and then tighten the other two alignment screws. (The recessed locking screws should all still be loosened a couple of turns at this point, per the NOTE above.)
6. Repeat the above procedure until the object stays at the center when the polar scope is rotated 180 degrees.

-
7. Lightly re-tighten the three recessed locking screws with a 2.5mm Allen key.

Be sure to turn the illuminator off when finished using the polar scope! Do this by rotating the battery cap counterclockwise until the red LED turns off. (Then rotate the small brightness dial in the same direction all the way.)

Powering the Illuminator

The Illuminated Polar Scope comes with a CR2032 lithium button cell battery, which powers the red LED that lights up the reticle. To install the battery, unscrew the battery cover (**Figure 2**) and insert the battery with the positive (+) side facing up. Then screw the battery cover back on.

The illuminator does not have an ON/OFF switch. To turn it on, you rotate the battery cap clockwise until the LED light comes on. You can adjust the brightness of the illumination with the brightness dial. To turn the illuminator off, rotate the battery cap counterclockwise until the LED light goes off.

One-Year Limited Warranty

This Orion product is warranted against defects in materials or workmanship for a period of one year from the date of purchase. This warranty is for the benefit of the original retail purchaser only. During this warranty period Orion Telescopes & Binoculars will repair or replace, at Orion's option, any warranted instrument that proves to be defective, provided it is returned postage paid. Proof of purchase (such as a copy of the original receipt) is required. This warranty is only valid in the country of purchase.

This warranty does not apply if, in Orion's judgment, the instrument has been abused, mishandled, or modified, nor does it apply to normal wear and tear. This warranty gives you specific legal rights. It is not intended to remove or restrict your other legal rights under applicable local consumer law; your state or national statutory consumer rights governing the sale of consumer goods remain fully applicable.

For further warranty information, please visit www.OrionTelescopes.com/warranty.

Orion Telescopes & Binoculars

Corporate Offices: 89 Hangar Way, Watsonville CA 95076 - USA

Customer Support: www.OrionTelescopes.com/contactus

Copyright © 2015 Orion Telescopes & Binoculars

All Rights Reserved. No part of this product instruction or any of its contents may be reproduced, copied, modified or adapted, without the prior written consent of Orion Telescopes & Binoculars.