

Orion EQ-1 Equatorial Mount

#9011



 **ORION**
TELESCOPES & BINOCULARS

Providing Exceptional Consumer Optical Products Since 1975

Customer Support:

www.OrionTelescopes.com/contactus

Corporate Offices:

89 Hangar Way, Watsonville CA 95076 - USA

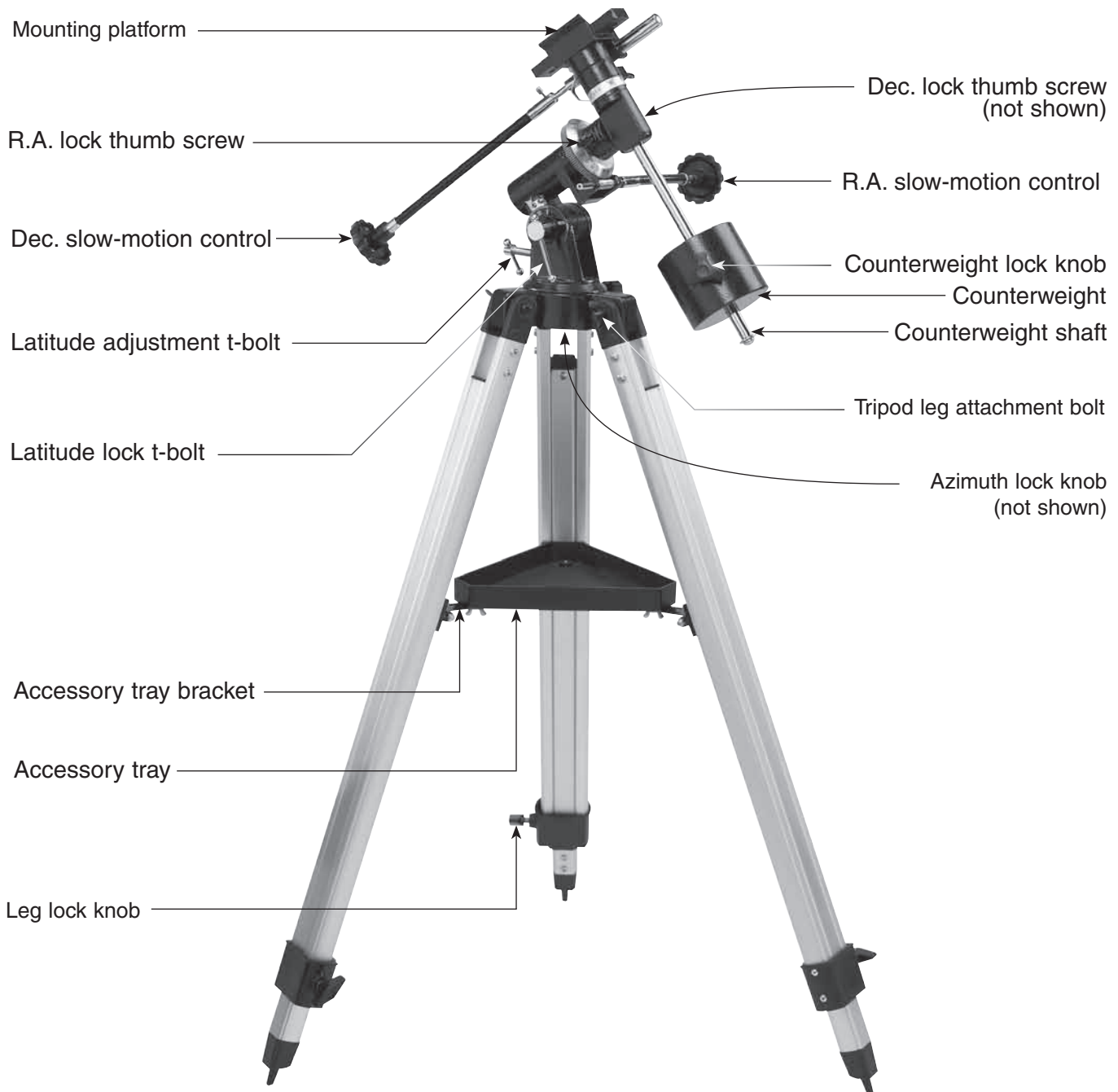

Figure 1. EQ-1 Equatorial Mount parts diagram

Congratulations on your purchase of a quality Orion product. Your new EQ-1 Equatorial Mount was designed to work with many different telescope optical tubes. With its precision equatorial head, you'll be able to easily track astronomical objects over time so that they remain within your eyepiece's field of view. The setting circles will help locate hundreds of fascinating celestial denizens, including galaxies, nebulas, and star clusters. With a little practice and a little patience, you'll find that your EQ-1 Equatorial Mount is an invaluable tool for getting the most out of your astronomical observing sessions.

These instructions will help you set up and properly use your equatorial mount. Please read them over thoroughly before getting started.

Table of Contents

1. Parts List.....	3
2. Assembly	3
3. Attaching A Telescope	4
4. Balancing the Telescope	5
5. Setting Up and Using the Equatorial Mount.....	6
6. Specifications.....	10
7. Suggested Accessories	10

1. Parts List

Qty.	Description
1	German-type equatorial mount
1	Latitude adjustment t-bolt
2	Slow-motion control cables
1	Counterweight (5 lb.)
1	Counterweight shaft
3	Tripod legs
3	Tripod leg attachment bolts with wing nuts and washers
3	Leg lock knobs
1	Accessory tray
3	Accessory tray screws with wing nuts
1	Assembly tool

Assembling the mount for the first time should take about 30 minutes. No tools are needed, other than the one provided. All bolts should be tightened securely to eliminate flexing and wobbling, but be careful not to over-tighten or the threads may strip. Refer to Figure 1 during the assembly process.

1. Lay the equatorial mount on its side. Attach the tripod legs, one at a time, to the base of the mount by sliding a tripod leg attachment bolt through the top of a leg and through the holes in the base of the mount. The washers should be on the outside of the tripod legs. Secure the wing nuts finger-tight. Note that the hinged accessory tray bracket on each leg should face inward.
2. Attach and tighten the leg lock knobs at the base of the tripod legs. For now, keep the legs at their shortest (fully retracted) length; you can extend them to a more desirable length later, after the mount is completely assembled.
3. With the tripod legs now attached to the equatorial mount, stand the tripod upright (be careful!) and spread the legs apart enough to attach the accessory tray to the three hinged tray brackets on the legs. The slots in the brackets should be positioned underneath the holes in the three corners of the tray. Use the three small accessory tray screws and wing nuts provided to fasten the tray to the brackets. Do not tighten the wing nuts yet.

2. Assembly

Carefully open all of the boxes in the shipping container. Make sure all the parts listed in Section 1 are present. Save the original boxes and packaging material. In the unlikely event that you need to return the telescope, you must use the original packaging. *Note: The EQ-1 Equatorial Mount is packaged with one empty interior box; the box is included for structural integrity only.*

4. With the accessory tray attached loosely, spread the tripod legs apart as far as they will go, until the accessory tray brackets are taut. Then tighten the wing nuts.
5. Next, tighten the wing nuts on the tripod leg attachment bolts at the base of the equatorial mount, so that the legs are securely fastened. You can use the provided assembly tool to hold the heads of the bolts while firmly tightening the wing nuts.
6. Thread the latitude adjustment t-bolt into the hole in the rear of the equatorial mount (see Figure 2). Orient the mount as it appears in Figure 2, at a latitude of about 40°, i.e., so that the pointer next to the latitude scale is pointing to the hash mark at "40." To do this, loosen the latitude lock t-bolt (central to the latitude scale), and turn the latitude adjustment t-bolt until the pointer and the "40" line up. Then re-tighten the latitude lock t-bolt. You may also need to rotate the mount about its right ascension (R.A.) and declination (Dec.) axes (see Figure 2). Do this by first loosening the R.A. and Dec. lock thumb screws.
7. Slide the counterweight onto the counterweight shaft. Make sure the counterweight lock knob is adequately loosened so the counterweight shaft can pass through the hole in the counterweight.
8. With the counterweight lock knob still loose, grip the counterweight with one hand and thread the shaft into the equatorial mount (at the base of the declination axis) with the other hand. When it is threaded as far in as it will go, position the counterweight about halfway up the shaft and tighten the counterweight

lock knob. The washer and screw on the end of the counterweight shaft will prevent the counterweight from slipping off the shaft and possibly onto your foot if the counterweight lock knob should come loose

9. Now attach the two slow-motion cables to the R.A. and Dec. slow-motion shafts (see Figure 2) of the equatorial mount by positioning the thumb screw on the end of the cable over the indented slot on the shaft, then tightening the thumb screw. A cable can be attached to either end of the R.A. shaft, whichever is most convenient for you. Use the shorter cable for the R.A. shaft.

3. Attaching a Telescope

The EQ-1 Equatorial Mount is designed to hold small to mid-size telescopes weighing up to about 7 lbs. For heavier telescopes, the mount may not provide sufficient stability for steady imaging. Any type of telescope can be mounted on the EQ-1 Equatorial Mount, including refractors, Newtonian reflectors, and catadioptrics, provided a proper adapter or set of tube rings is available to couple the tube to the mount.

Orion carries a variety of differently sized tube rings and a 1/4"-20 mounting adapter designed exclusively for the EQ-1 Equatorial Mount. One of these items probably fits the telescope tube you wish to mount. See the list of Suggested Accessories at the end of these instructions, or check the Orion print or online catalogs for currently available mounting accessories.

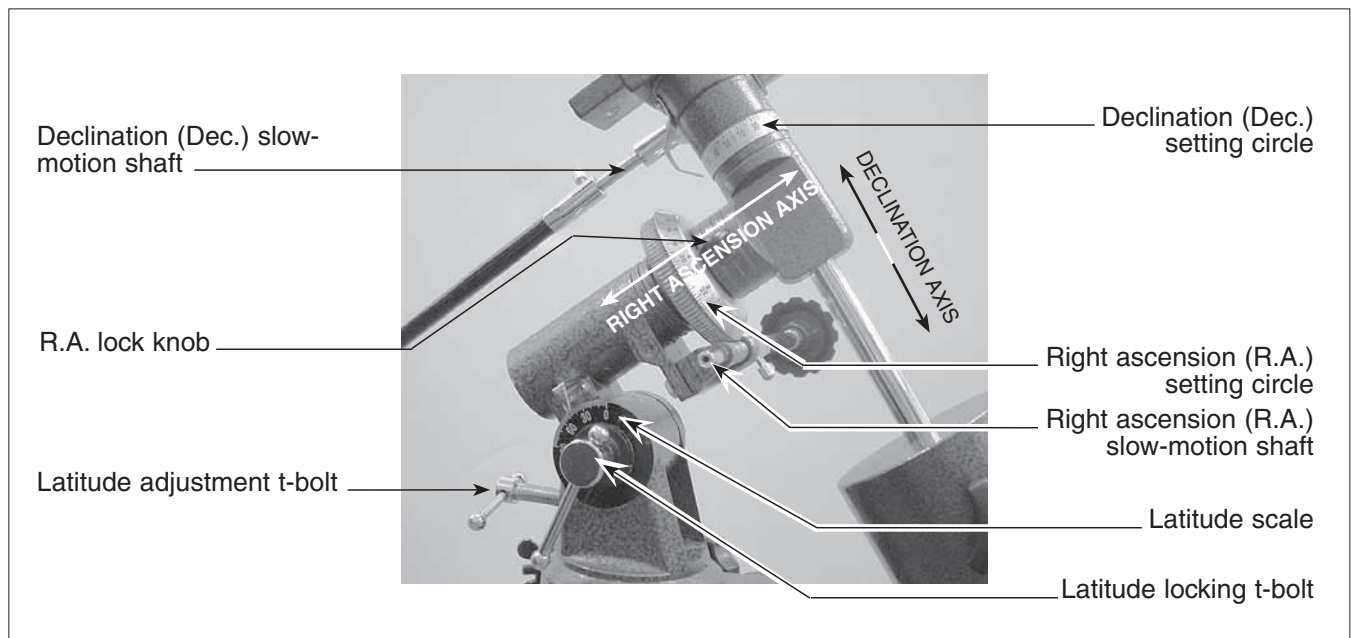

Figure 2. The equatorial mount

The mounting accessories fasten to the two holes in the top platform of the equatorial mount.

4. Balancing the Telescope

Once the telescope is attached to the equatorial mount, the next step is to balance the telescope. Proper balance is required to insure smooth movement of the telescope on both axes of the equatorial mount.

If you attach your telescope with a 1/4"-20 adapter, it may not be possible to balance the scope precisely with respect to the declination axis, because the telescope cannot be moved back and forth as it can when tube rings are used.

Assuming you will be using tube rings, we will first balance the telescope with respect to the R.A. axis, then the Dec. axis.

1. Keeping one hand on the telescope optical tube, loosen the R.A. lock thumb screw. Make sure the Dec. lock thumb screw is locked, for now. The telescope should now be able to rotate freely about the R.A. axis. Rotate it until the counterweight shaft is parallel to the ground (i.e., horizontal).
2. Now loosen the counterweight lock knob and slide the weight along the shaft until it exactly counterbalances the telescope (Figure 3a). That's the point at which the shaft remains horizontal even when you let go of the telescope with both hands (Figure 3b). Retighten the counterweight lock knob. The telescope is now balanced on the R.A. axis.
3. To balance the telescope on the Dec. axis (this is not possible if using a 1/4"-20 mounting adapter), first tighten the R.A. lock thumb screw, with the counterweight shaft still in the horizontal position.
4. With one hand on the telescope optical tube, loosen the Dec. lock thumb screw (Figure 3c). The telescope should now be able to rotate freely about the Dec. axis.

Loosen the tube ring clamps a few turns until you can slide the telescope tube forward and back inside the rings (this can be aided by using a slight twisting motion on the optical tube while you push or pull on it) (Figure 3d). Position the telescope so that it remains horizontal when you carefully let go with both hands. This is the balance point for the Dec. axis (Figure 3e). Before clamping the rings tight again, rotate the telescope so that the eyepiece is at a convenient angle for viewing.



Figure 3a. Balancing the telescope with respect to the R.A. axis by sliding the counterweight along its shaft.



Figure 3b. Telescope is now balanced on the R.A. axis. That is, when hands are released, counterweight shaft remains horizontal.



Figure 3c. Preparing the telescope to be balanced on the Dec. axis by first releasing the Dec. lock knob.



Figure 3d. Balancing the telescope with respect to the Dec. axis. As shown here, the telescope is out of balance (tilting).



Figure 3e. Telescope is now balanced on the Dec. axis, i.e., it remains horizontal when hands are released.

The telescope is now balanced on both axes. Now when you loosen the lock thumb screw on one or both axes and manually point the telescope, it should move without resistance and should not drift from where you point it.

5. Setting Up and Using the Equatorial Mount

When you look at the night sky, you no doubt have noticed that the stars appear to move slowly from east to west over time. That apparent motion is caused by the Earth's rotation (from west to east). An equatorial mount (Figure 2) is designed to compensate for that motion, allowing you to easily "track" the movement of astronomical objects, thereby keeping them from drifting out of the telescope's field of view while you're observing.

This is accomplished by slowly rotating the telescope on its right ascension (polar) axis, using only the R.A. slow-motion cable. But first the R.A. axis of the mount must be aligned with the Earth's rotational (polar) axis; this is a process called polar alignment.

Polar Alignment

For Northern Hemisphere observers, approximate polar alignment is achieved by pointing the mount's R.A. axis at the North Star, or Polaris. It lies within 1° of the north celestial pole (NCP), which is an extension of the Earth's rotational axis out into space. Stars in the Northern Hemisphere appear to revolve around Polaris.

To find Polaris in the sky, look north and locate the pattern of the Big Dipper (Figure 4). The two stars at the end of the "bowl" of the Big Dipper point right to Polaris.

Observers in the Southern Hemisphere aren't so fortunate to have a bright star so near the south celestial pole (SCP). The star Sigma Octantis lies about 1° from the SCP, but it is barely visible with the naked eye (magnitude 5.5).

For general visual observation, an approximate polar alignment is sufficient:

1. Level the equatorial mount by adjusting the length of the three tripod legs.
2. Loosen the latitude lock t-bolt. Turn the latitude adjustment t-bolt and tilt the mount until the pointer on the latitude scale is set at the latitude of your observing site. If you don't know your latitude, consult a geographical atlas to find it. For example, if your latitude is 35° North, set the pointer to +35. Then retighten the latitude lock t-bolt. The latitude setting should not have to be adjusted again unless you move to a different viewing location some distance away.
3. Loosen the Dec. lock thumb screw and rotate the telescope optical tube until it is parallel with the R.A. axis. The pointer on the Dec. setting circle should read 90° . Retighten the Dec. lock thumb screw.

- Loosen the azimuth adjustment knob and rotate the entire equatorial mount left-to-right so the telescope tube (and R.A. axis) points roughly at Polaris. If you cannot see Polaris directly from your observing site, consult a compass and rotate the equatorial mount so the telescope points North. Retighten the azimuth adjustment knob.

The equatorial mount is now approximately polar-aligned for casual observing. More precise polar alignment is required for astrophotography. Several methods exist and are described in many amateur astronomy reference books and astronomy magazines.

From this point on in your observing session, you should not make any further adjustments to the azimuth or the latitude of the mount, nor should you move the tripod. Doing so will undo the polar alignment. The telescope should be moved only about its R.A. and Dec. axes.

Use of the R.A. and Dec. Slow-Motion Control Cables

The R.A. and Dec. slow-motion control cables allow fine adjustment of the telescope's position to center objects within the field of view. Before you can use the cables, you must manually "slew" the mount to point the telescope in the vicinity of the desired target. Do this by loosening the R.A. and Dec. lock thumb screws and moving the telescope about the mount's R.A. and Dec. axes. Once the telescope is pointed somewhere close

to the object to be viewed, retighten the mount's R.A. and Dec. lock thumb screws.

The object should now be visible somewhere in the telescope's (aligned) finder scope. If it isn't, use the slow-motion controls to scan the surrounding area of sky. If the object is still not visible in the finder scope, you will need to slew the mount again, this time being more careful to point the telescope closer to what you wish to view.

When the object is visible in the finder scope, use the slow-motion controls to center it. Now, look in the telescope with a long focal length (low magnification) eyepiece. If the finder scope is properly aligned, the object should be visible somewhere in the field of view. If it is not, you may need to realign the telescope's finder scope.

Once the object is visible in the telescope's eyepiece, use the slow-motion controls to center it in the field of view. You can now switch to a higher magnification eyepiece, if you wish. After switching eyepieces, you can use the slow-motion control cables to re-center the image, if necessary.

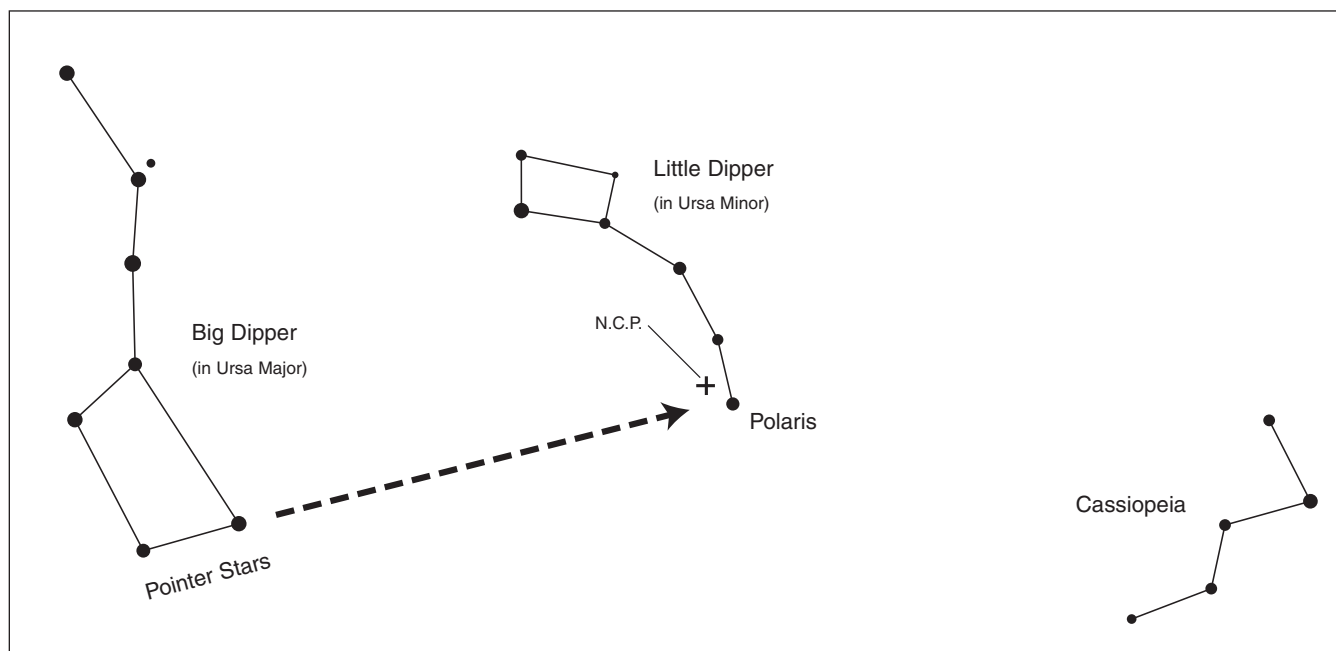

To find Polaris in the night sky, look north and find the Big Dipper. Extend an imaginary line from the two "Pointer Stars" in the bowl of the Big Dipper. Go about 5 times the distance between those stars and you'll reach Polaris, which lies within 1° of the north celestial pole (NCP).

Figure 4. Finding Polaris

The Dec. slow-motion control cable can move the telescope a maximum of 25°. This is because the Dec. slow-motion mechanism has a limited range of mechanical travel. (The R.A. slow-motion mechanism has no limit to its amount of travel.) If you can no longer rotate the Dec. control cable in a desired direction, you have reached the end of travel, and the slow-motion mechanism should be reset. This is done by first rotating the control cable several turns in the opposite direction from which it was originally being turned. Then, manually slew the telescope closer to the object you wish to observe (remember to first loosen the Dec. lock thumb screw). You should now be able to use the Dec. slow-motion control cable again to fine adjust the telescope's position.

Tracking Celestial Objects

When you observe a celestial object through the telescope, you'll see it drift slowly across the field of view. To keep it in the field, if your equatorial mount is polar-aligned, just rotate the R.A. slow-motion control. The Dec. slow-motion control is not needed for tracking. Objects will appear to move faster at higher magnifications, because the field of view is narrower.

Optional Motor Drives for Automatic Tracking and Astrophotography

An optional DC motor drive (EQ-1M) can be mounted on the R.A. axis of the EQ-1 Equatorial Mount to provide hands-free tracking. Objects will then remain stationary in the field of view without any manual adjustment of the R.A. slow-motion control. The motor drive is necessary for astrophotography.

If mounting only a DSLR camera with lens on the mount, note that the included 5-lb. counterweight could interfere with, i.e., contact, the motor drive when the camera is pointed in certain orientations. To avoid this problem, you should replace the 5-lb. counterweight with the narrower, 2.1-lb. counterweight (#7398, sold separately). With this counterweight there is complete clearance from the motor drive in any camera orientation.

Understanding the Setting Circles

The setting circles on an equatorial mount enable you to locate celestial objects by their "celestial coordinates." Every astronomical object resides in a specific location on the "celestial sphere." That location is denoted by two numbers: its right ascension (R.A.) and declination (Dec.). In the same way, every location on Earth can be described by its longitude and latitude. R.A. is similar to longitude on Earth, and Dec. is similar to latitude. The R.A. and Dec. values for celestial objects can be found in any star atlas or star catalog.

So, the coordinates for the Orion Nebula listed in a star atlas will look like this:

R.A. 5h 35.4m Dec. -5° 27'

That's 5 hours and 35.4 minutes in right ascension, and -5 degrees and 27 arc-minutes in declination (the negative sign denotes south of the celestial equator). There are 60 minutes in 1 hour of R.A. and there are 60 arc-minutes in 1 degree of declination.

The mount's R.A. setting circle is scaled in hours, from 1 through 24, with small hash marks in between representing 10 minute increments. The numbers closest to the R.A. axis gear apply to viewing in the Southern Hemisphere, while the numbers above them apply to viewing in the Northern Hemisphere. The Dec. setting circle is scaled in degrees, with each small hash mark representing 2.5°.

Before you can use the setting circles to locate objects, the mount must be well polar aligned, and the setting circles must be calibrated. The declination setting circle was calibrated at the factory, and should read 90° when the telescope optical tube is parallel with the R.A. axis.

Calibrating the Right Ascension Setting Circle

1. Identify a bright star near the celestial equator and look up its coordinates in a star atlas.
2. Loosen the R.A. and Dec. lock thumb screws on the equatorial mount, so the telescope optical tube can move freely.
3. Point the telescope at the bright star near the celestial equator whose coordinates you know. Center the star in the telescope's field of view. Lock the R.A. and Dec. lock thumb screws.
4. Rotate the R.A. setting circle so the pointer indicates the R.A. listed for the bright star in the star atlas.

Finding Objects With the Setting Circles

Now that both setting circles are calibrated, look up in a star atlas the coordinates of an object you wish to view.

1. Loosen the Dec. lock thumb screw and rotate the telescope until the Dec. value from the star atlas matches the reading on the Dec. setting circle. Retighten the lock thumb screw. *Note: If the telescope is aimed south and the Dec. setting circle pointer passes the 0° indicator, the value on the Dec. setting circle becomes a negative number.*
2. Loosen the R.A. lock thumb screw and rotate the telescope until the R.A. value from the star atlas matches the reading on the R.A. setting circle. Retighten the lock thumb screw.

Most setting circles are not accurate enough to put an object dead-center in your finder scope's field of view, but they'll get you close, assuming the equatorial mount is accurately polar-aligned. The R.A. setting circle should be re-calibrated every time you wish to locate a new object. Do so by calibrating the setting circle for the centered object before moving on to the next one.

Confused About Pointing the Telescope?

Beginners occasionally experience some confusion about how to point the telescope overhead or in other directions. In Figure 1 the telescope is pointed north as it would be during polar alignment. The counterweight shaft is oriented downward. But it will not look like that when the telescope is pointed in other directions. Let's say you want to view an object that is directly overhead, at the zenith. How do you do it?

One thing you DO NOT do is make any adjustment to the latitude adjustment t-bolt. That will nullify the mount's polar alignment. Remember, once the mount is polar-aligned, the telescope should be moved only on the R.A. and Dec. axes. To point the scope overhead, first loosen the R.A. lock thumb screw and rotate the telescope on the R.A. axis until the counterweight shaft is horizontal (parallel to the ground). Then loosen the Dec. lock thumb screw and rotate the telescope until it is pointing straight overhead. The counterweight shaft is still horizontal. Then retighten both lock thumb screws.

Similarly, to point the telescope directly south, the counterweight shaft should again be horizontal. Then you simply rotate the scope on the Dec. axis until it points in the south direction. (Figure 5a)



Figure 5a. Telescope pointing south. Note that in all these illustrations, the mount and tripod remain stationary; only the R.A. and Dec. axes are moved.



Figure 5b. Telescope pointing north.



Figure 5c. Telescope pointing east.

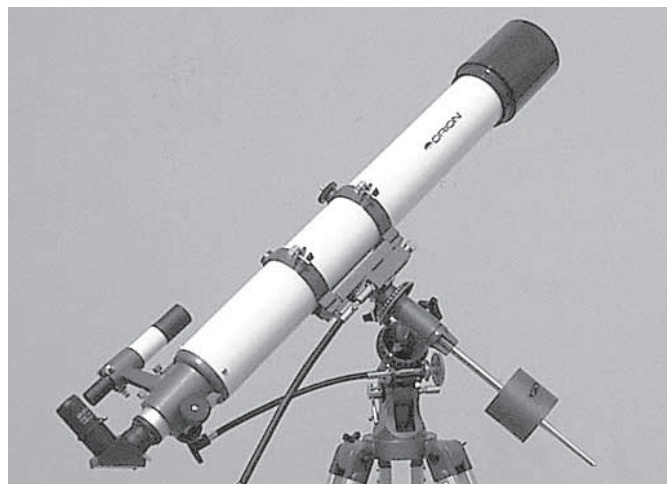

Figure 5d. Telescope pointing west.

What if you need to aim the telescope directly north, but at an object that is nearer to the horizon than Polaris? You can't do it with the counterweight down as pictured in Figure 1. Again, you have to rotate the scope in R.A. so that the counterweight shaft is positioned horizontally. Then rotate the scope in Dec. so it points to where you want it near the horizon. (Figure 5b)

To point the telescope to the east (Figure 5c) or west (Figure 5d), or in other directions, you rotate the telescope on its R.A. and Dec. axes. Depending on the altitude of the object you want to observe, the counterweight shaft will be oriented somewhere between vertical and horizontal.

The key things to remember when pointing the telescope is that a) you only move it in R.A. and Dec., not in azimuth or latitude (altitude), and b) the counterweight and shaft will not always appear as it does in Figure 1. In fact it almost never will!

6. Specifications

Mount: German-type equatorial

Tripod: aluminum

Height: 36" to 57"

Weight: 11.9 lbs

Counterweight: 5 lb.

Maximum Loading Weight: about 7 lbs.

Slow-Motion Adjustment: both RA and Dec axes

Setting Circles: RA scaled in 10 min. increments, Dec scaled in 2.5° increments, for N or S Hemisphere

Polar Axis Altitude Adjustment: 10° to 70°

7. Suggested Accessories

1/4"-20 Adapter (Orion part #10103)

This accessory bolts to the top of the equatorial head and provides a threaded post on which to mount a camera or telescope that utilizes a standard 1/4"-20 thread.

Tube Mounting Rings

Orion carries a wide variety of tube rings to couple different sizes of telescope to the EQ-1 mount. The tube rings attach directly to the mounting platform on the EQ head. Visit our website (www.telescope.com) for more information.

EQ-1M Motor Drive (Orion part #7826)

This is a small electric motor that attaches to the equatorial mount. It turns the gear on the R.A. axis at the same rate that the Earth rotates on its axis, thereby following, or "tracking," the apparent motion of the stars. Automatic tracking keeps objects from drifting out of the field of view while you're observing, and is required for astrophotography. Runs on four size "D" alkaline batteries, not included.

One-Year Limited Warranty

This Orion product is warranted against defects in materials or workmanship for a period of one year from the date of purchase. This warranty is for the benefit of the original retail purchaser only. During this warranty period Orion Telescopes & Binoculars will repair or replace, at Orion's option, any warranted instrument that proves to be defective, provided it is returned postage paid. Proof of purchase (such as a copy of the original receipt) is required. This warranty is only valid in the country of purchase.

This warranty does not apply if, in Orion's judgment, the instrument has been abused, mishandled, or modified, nor does it apply to normal wear and tear. This warranty gives you specific legal rights. It is not intended to remove or restrict your other legal rights under applicable local consumer law; your state or national statutory consumer rights governing the sale of consumer goods remain fully applicable.

For further warranty information, please visit www.OrionTelescopes.com/warranty.

Orion Telescopes & Binoculars
Corporate Offices: 89 Hangar Way, Watsonville CA 95076 - USA
Customer Support: www.OrionTelescopes.com/contactus

© Copyright 2009-2013 Orion Telescopes & Binoculars