

Orion 150mm f/12 Maksutov-Cassegrain

#9967 Optical Tube Assembly

Your new 150mm Maksutov-Cassegrain (Mak-Cass) telescope is a fine-quality instrument designed for both daytime terrestrial viewing and nighttime stargazing. Compact and portable, but packing long focal length optics for prodigious power, this versatile scope will provide many hours of enjoyment.

These instructions will help you set up and properly use and care for your telescope. Please read them over thoroughly before getting started.

Getting Started

Your telescope comes fully assembled from the factory. The optics have been installed and collimated, so you should not have to make any adjustments to them. Keep the dust covers on the telescope when it is not in use. Please keep the original shipping box. In the unlikely event you should need to ship the telescope back to Orion for warranty repair service, you should use the original packaging. The box also makes a very good container for storing the telescope.

The Maksutov-Cassegrain optical system of this telescope consists of both a spherical primary mirror in the back and a full-aperture concave “meniscus” lens, sometimes called the corrector lens, in front. The lens, which also has a spherical figure, effectively corrects optical aberrations such as coma and spherical aberration produced by the mirror design alone. This optical design is a closed system that requires little, if any, maintenance.

Mounting the Telescope

The Vixen-style dovetail mounting plate on the 150mm Maksutov-Cassegrain (**Figure 1**) is specifically designed to couple directly to any mount with a compatible Vixen-style mounting saddle.

There are two 1/4"-20 (and two M6x1.0) threaded holes in the dovetail mounting plate for attachment of the 150mm Mak-Cass optical tube assembly to a sturdy photo tripod or altazimuth mount equipped with a 1/4"-20 mounting stud. We don't recommend this method of attachment for photo tripods, however, due to the heavy weight of the telescope (11.5 lbs. not including accessories), which is more than most consumer photo tripods can typically handle well.



The 2" Visual Back Adapter

Your telescope comes equipped with a 2" visual back adapter on the rear cell, for use with 2" accessories (**Figure 2**). The 2" visual back includes a 2"-to-1.25" step-down adapter that accommodates 1.25" accessories. The telescope does not come with any accessories; this gives you the greatest flexibility in configuring it to your needs.

To install a 2" diagonal, first remove the 1.25" adapter by loosening the two thumbscrews on the 2" visual back, then insert the barrel of the diagonal. Secure it in place with the two thumbscrews. Then insert an eyepiece into the diagonal and secure it with the thumbscrew(s) on the diagonal. To insert a 1.25" diagonal instead of a 2" diagonal, leave the 1.25" adapter in the 2" visual back, and insert the barrel of the 1.25" diagonal into the 1.25" adapter. Secure it in place with the thumbscrew.

Add an Optional Finder Scope

The included finder scope dovetail base on the 150mm Maksutov-Cassegrain (**Figure 1**) is ready to accept any Orion finder scope or reflex sight. To install the finder scope, simply slide the finder scope's dovetail bracket into the dovetail base and secure the bracket in place by tightening the thumbscrew lock on the base. You'll then need to align the finder scope with the optical axis of the 150mm Maksutov-Cassegrain.



Figure 1. Features of the 150mm f/12 Maksutov-Cassegrain

Customer Support (800)-676-1343
E-mail: support@telescope.com

Corporate Offices (831)-763-7000
89 Hangar Way, Watsonville, CA 95076

Copyright © 2015 Orion Telescopes & Binoculars

All Rights Reserved. No part of this product instruction or any of its contents may be reproduced, copied, modified or adapted, without the prior written consent of Orion Telescopes & Binoculars.

Focusing

The focus knob on the rear cell of the telescope slides the primary mirror inside the telescope forward and back to change the focus point. When you first look in the eyepiece, the image you see may be fuzzy, or out of focus. If it is, gently turn the focus knob with your fingers in either direction until the image gets sharper. Go a little bit beyond sharp focus until the image just starts to blur again, then reverse the rotation of the knob, just to make sure you've hit the exact focus point. You will have to readjust the focus when aiming at subjects of varying distances, or after changing eyepieces (if they are not parfocal). If you have trouble focusing or can't see much of anything in the eyepiece, rotate the focus knob counterclockwise as far as it will go. Now look through the eyepiece while slowly rotating the focus knob clockwise. You should soon see the point at which focus is reached.

Know Your Power

Your 150mm Maksutov-Cassegrain has a long 1800mm focal length, which means it will achieve fairly high magnifications with standard focal length eyepieces. This has its advantages, of course, for observing small objects and resolving fine detail. But remember that the steadiness of the air (the "seeing") will limit how much magnification an image can tolerate.

To calculate the magnification, or power, of a telescope with an eyepiece, simply divide the focal length of the telescope by the focal length of the eyepiece you're using:

Telescope Focal Length (mm) / Eyepiece Focal Length (mm) = Magnification

So for the 150mm Maksutov-Cassegrain, using a 25mm eyepiece will yield a magnification of 72x:

1800mm / 25mm = 72x

And using a 10mm eyepiece will yield a magnification of 180x (1800 / 10 = 180x).

Every telescope has a useful limit of power of about 2x per millimeter of aperture, which is about 300x for the 150mm Mak-Cass. And that will only produce a clean, well resolved image under the very best seeing conditions and with very well made optics – including the eyepiece and diagonal. Most of the time you'll get better views at much lower powers.

Start viewing with your lowest-power (longest focal length) eyepiece in the telescope. It's best to begin observing with the lowest-power eyepiece, because it will typically provide the widest true field of view, which will make finding and centering objects much easier. After you have located and centered an object, you can try switching to a higher-power eyepiece to ferret out more detail, if atmospheric conditions permit. If the image you see is not crisp and steady, reduce the magnification by switching to a longer focal length eyepiece. As a general rule, a small but well-resolved image will show more detail and provide a more enjoyable view than a dim and fuzzy, over-magnified image.

Terrestrial Viewing

For daytime land viewing, we recommend using a "correct

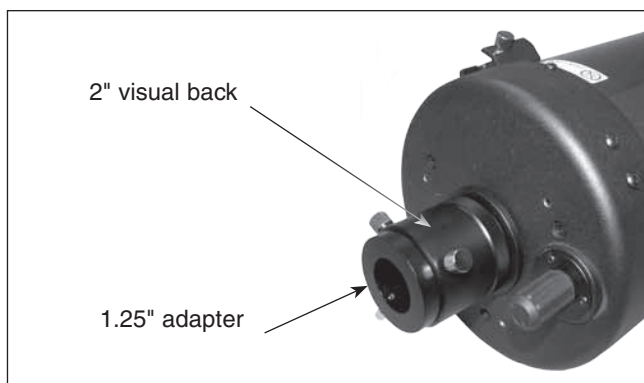

Figure 2. The 2" visual back and 1.25" adapter allow use of both 2" and 1.25" accessories.

image" 45-degree diagonal so that the image viewed through the telescope is oriented correctly. With a "star diagonal," typically used for astronomical viewing, the image in the 150mm Maksutov-Cassegrain would be mirror reversed. For terrestrial viewing you will also probably want a correct-image finder scope, as a standard finder scope produces an upside-down view. That's not a big deal for astronomy, but for terrestrial viewing is not ideal.

For daytime terrestrial viewing it's best to stick with low power eyepieces that yield a magnification under 100x. At higher powers, images rapidly lose sharpness and clarity due to "heat waves" caused by Sun-heated air. Remember to aim well clear of the Sun, unless the front of the telescope is fitted with a professionally made solar filter and the finder scope is covered with a completely opaque material or removed altogether.

Care & Maintenance

If you give your telescope reasonable care, it will last a lifetime. When not in use, keep the dust cover on the front of the tube and the dust cap on the eyepiece adapter. Store it in a clean, dry, dust-free place, safe from rapid changes in temperature and humidity. Do not store the telescope outdoors, although storage in a garage or shed is OK.

Your telescope requires very little mechanical maintenance. The optical tube is aluminum and has a smooth painted finish that is fairly scratch-resistant. If a scratch does appear on the tube, it will not harm the telescope. If you wish, you may apply some auto touch-up paint to the scratch. Smudges on the tube can be wiped off with a soft cloth and household cleaning fluid.

Any quality optical lens cleaning tissue and optical lens cleaning fluid specifically designed for multi-coated optics can be used to clean the front meniscus lens of the telescope. Never use regular glass cleaner or cleaning fluid designed for eyeglasses. Before cleaning with fluid and tissue, however,

WARNING: *Never look directly at the Sun through your telescope—even for an instant—without a professionally made solar filter that completely covers the front of the instrument, or permanent eye damage could result. Young children should use this telescope only with adult supervision.*

blow any loose particles off the lens with a blower bulb or compressed air. Then apply some cleaning fluid to a tissue, never directly on the optics. Wipe the lens gently, then remove any excess fluid with a fresh lens tissue. Oily fingerprints and smudges may be removed using this method. Use caution; rubbing too hard may scratch the lens. For the large surface of the meniscus lens, clean only a small area at a time, using a fresh lens tissue on each area. Never reuse tissues.

Appendix: Collimating the Optics

Collimating is the process of aligning a telescope's optics. Your Maksutov-Cassegrain's primary mirror was aligned at the factory and should not need adjustment unless the telescope is handled roughly. This manual contains information on how to test the collimation of your telescope and instructions for proper alignment should that be needed.

Star-Testing the Telescope

Before you start adjusting the primary mirror of your telescope, make certain that it is actually out of collimation by performing a star test. Take your telescope out at dusk and let it acclimate to the outside temperature; this usually takes 30-60 minutes. When it is dark, point the telescope upwards at a bright star and accurately center it in the eyepiece's field of view. Slowly de-focus the image with the focusing knob. If the telescope is correctly collimated, the expanding disk should be a circle (**Figure 3**). If the image is unsymmetrical, the scope is out of collimation. Also, the dark shadow cast by the secondary mirror should appear in the very center of the out-of-focus circle, like the hole in a donut. If the "hole" appears off-center, the telescope is out of collimation.

If you try the star test but the bright star you have selected is not accurately centered in the eyepiece, the optics will always appear out of collimation, even though they may be perfectly aligned. It is critical to keep the star centered, so over time you will need to make slight corrections to the telescope's position in order to account for the sky's apparent motion.

Collimation Procedure

To collimate your telescope, remove the diagonal and eyepiece and look into rear opening of the tube (also remove the dust cover from the front of the tube). This should be done indoors, with the telescope pointed at a white wall in a well-lit room. Try to keep your eye centered with respect to the rear opening of the tube as best as possible. Using an Orion Collimating Eyepiece will aid greatly in keeping your eye centered and is strongly recommended.

If your telescope is out of collimation, what you see will resemble **Figure 4A**. A properly collimated scope will resemble **Figure 4B**. The direction of the misalignment in your telescope may differ from **Figure 4A**, but the diagram will give you the general idea of how things will look. Note there are three pairs of alignment screws on the rear cell of the optical tube (**Figure 5**), with each pair consisting of a large and a small screw. You will need 4mm and 2.5mm metric Allen wrenches to turn these screws. Each pair of collimation screws work together to adjust the tilt of the primary mirror. One screw pushes the mirror cell forward, while the other screw pulls the

mirror cell back. One must be loosened and the other tightened by equal amounts in order to adjust the tilt.

Look into the rear opening of the tube and locate the black crescent that indicates the optics are out of collimation. Note which way the front of the telescope would need to move in order to "fill" that black crescent and resemble **Figure 4B**. Then look at the back end of the telescope and locate the pair of collimation screws that are nearest to the direction that the front of the telescope needs to move. Tighten one of these screws by one turn, and loosen the other screw of the pair by one turn. Look into the rear opening of the tube and determine if the black crescent has reduced in size, increased in size, or been "filled." If the crescent has reduced in size, continue adjusting the pair of collimation screws in the same manner until the crescent has been completely "filled." If the crescent has increased in size, the optics have been moved further out of alignment. To correct this, loosen and tighten the same pair of collimation screws by one turn to undo the previous adjustment. Then adjust the other two pairs of collimation screws until the black crescent is "filled."

It will take a little trial and error to get a feel for how to tilt the mirror using the collimation screw pairs. Again, collimation

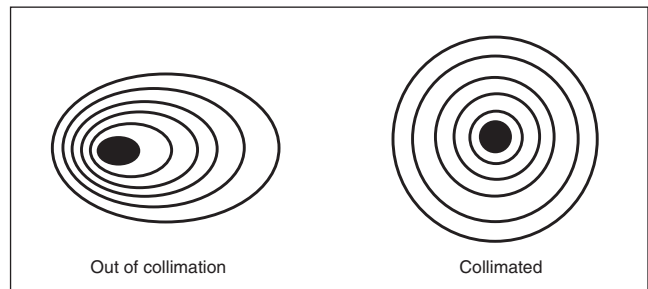

Figure 3. A star test will determine if a telescope's optics are properly collimated. An unfocused view of a bright star through the eyepiece should appear as illustrated on right if optics are perfectly collimated. If circle is unsymmetrical, as in illustration on left, the scope needs collimation.

should only be attempted if you have confirmed the telescope is actually out of collimation by performing a star test.

Note: *the secondary mirror of the 150mm Maksutov-Cassegrain is not adjustable.*

Finishing Collimation

Once you have finished adjusting your telescope, you should perform another star test (described earlier) to check the collimation. If your telescope appears collimated after star testing, it should not need adjustment again unless it is roughly handled. If you have gone through this process and your telescope is still out of collimation, please contact Orion customer support. You may need to return the telescope for repair or replacement (covered under warranty for 1 year after purchase).

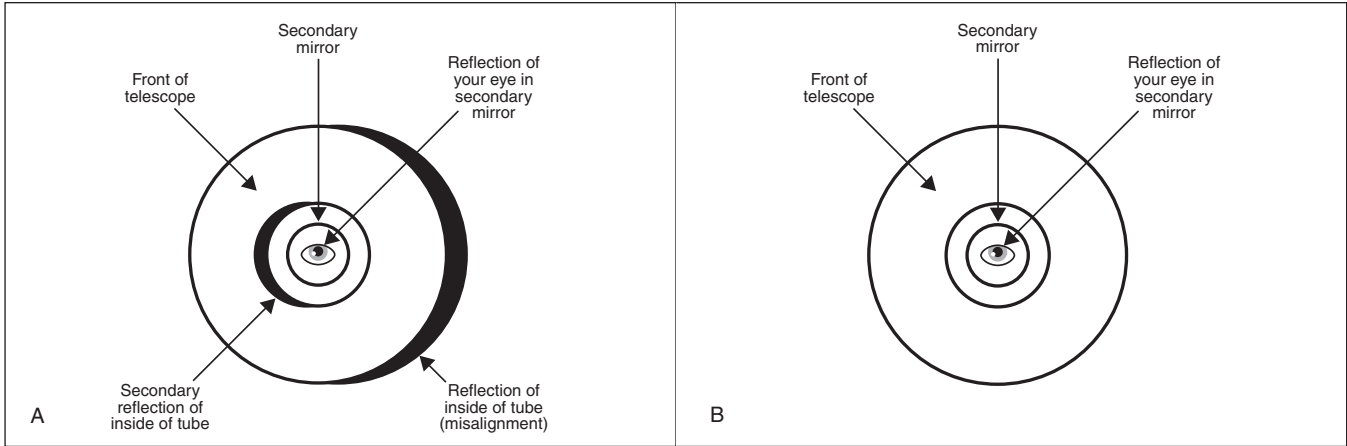

Figure 4 A) If the telescope's optics are out of alignment, the view through the rear opening of the telescope will look like this. **B)** When the optics are properly collimated the view will look like this.

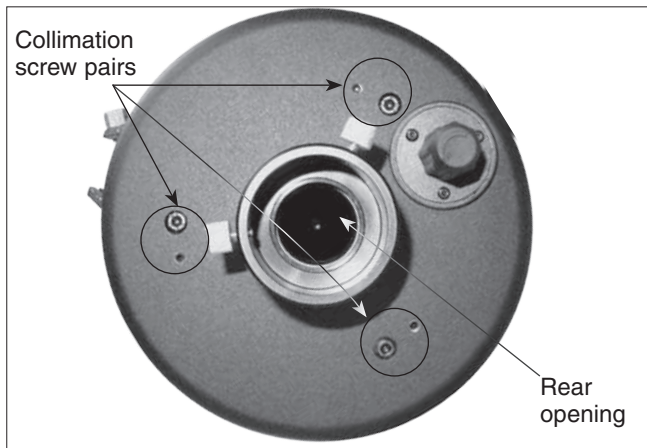

Figure 5. The primary mirror collimation screws of the 150mm Maksutov-Cassegrain.

Specifications

Optical design: Maksutov-Cassegrain

Aperture: 150mm (5.9")

Effective focal length: 1800mm

Focal ratio: f/12.0

Central obstruction diameter: 47mm

Primary mirror coating: Aluminum with SiO₂ overcoat

Meniscus lens coating: Anti-reflection multi-coatings on both sides of lens

Eyepiece adapter: 2" visual back with 1.25" adapter; accepts 2" or 1.25" accessories

Optical tube mounting plate: Vixen-style

Weight: 11.5 lbs

Length: 17.75"

Diameter: 7.75"

One-Year Limited Warranty

This Orion 150mm Maksutov-Cassegrain Telescope is warranted against defects in materials or workmanship for a period of one year from the date of purchase. This warranty is for the benefit of the original retail purchaser only. During this warranty period Orion Telescopes & Binoculars will repair or replace, at Orion's option, any warranted instrument that proves to be defective, provided it is returned postage paid to: Orion Warranty Repair, 89 Hangar Way, Watsonville, CA 95076. If the product is not registered, proof of purchase (such as a copy of the original invoice) is required.

This warranty does not apply if, in Orion's judgment, the instrument has been abused, mishandled, or modified, nor does it apply to normal wear and tear. This warranty gives you specific legal rights, and you may also have other rights, which vary from state to state. For further warranty service information, contact: Customer Service Department, Orion Telescopes & Binoculars, 89 Hangar Way, Watsonville, CA 95076; (800)-676-1343.

Orion Telescopes & Binoculars

89 Hangar Way, Watsonville, CA 95076

Customer Support Help Line (800)-676-1343 • Day or Evening

Copyright © 2015 Orion Telescopes & Binoculars

All Rights Reserved. No part of this product instruction or any of its contents may be reproduced, copied, modified or adapted, without the prior written consent of Orion Telescopes & Binoculars.