

INSTRUCTION MANUAL

Orion® SteadyPix™ Pro Universal Camera/ Smartphone Photo Mount #5306

Congratulations on your purchase of the SteadyPix Pro Universal Camera/Smartphone Mount. This versatile adapter enables you to take high-magnification telescopic photographs with a wide variety of point-and-shoot digital cameras and smartphones.

The SteadyPix Pro firmly holds your camera or smartphone up to the eyepiece of a telescope or spotting scope, providing the critical positioning needed to capture sharply focused, consistently well-composed terrestrial shots or nighttime

astrophotos through the telescope's optics – with jaw-dropping results!

These instructions provide a brief outline of how to set up and use the SteadyPix Pro. Please read them carefully prior to using it for the first time.

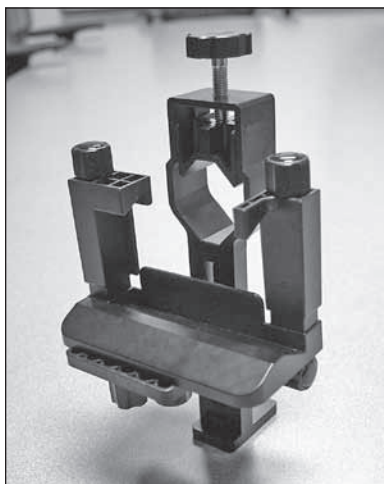

 **ORION®**
TELESCOPES & BINOCULARS

Providing Exceptional Consumer Optical Products Since 1975

OrionTelescopes.com

Customer Support (800) 676-1343

E-mail: support@telescope.com

Corporate Offices (831) 763-7000

89 Hangar Way, Watsonville, CA 95076

© 2013 Orion Telescopes & Binoculars

Included Parts

Qty	Item
1	SteadyPix camera mount
1	Smartphone holder
2	Smartphone bracket attachment knobs

About Afocal Photography

The SteadyPix Pro lets you couple almost any small digital camera and popular models of smartphone to a telescope to do “afocal” photography. In the afocal method, the camera lens is aimed into the telescope eyepiece.

While it is possible to take pictures by holding a camera up to the eyepiece by hand, small movements of the camera make it difficult to maintain perfect, consistent focus and framing of your subject. SteadyPix Pro eliminates those problems by positioning the camera firmly and precisely and locking it in that optimum position relative to the eyepiece. This coupling also allows the camera to move in synchrony with the eyepiece if the telescope is electronically driven to “track” celestial objects.

To get the best pictures with the SteadyPix Pro, we recommend using telescope eyepieces with long “eye relief” of 15mm or more. Long eye relief will allow the camera to see the whole field of view in the eyepiece.

Refer to **Figure 1** to familiarize yourself with the various parts of the SteadyPix Pro, as they will be referred to in these instructions.

For Digital Cameras

The SteadyPix Pro is designed for use with small, digital point-and-shoot cameras or very compact SLR cameras. It is not suitable for standard-size DSLRs as they are too bulky and heavy.

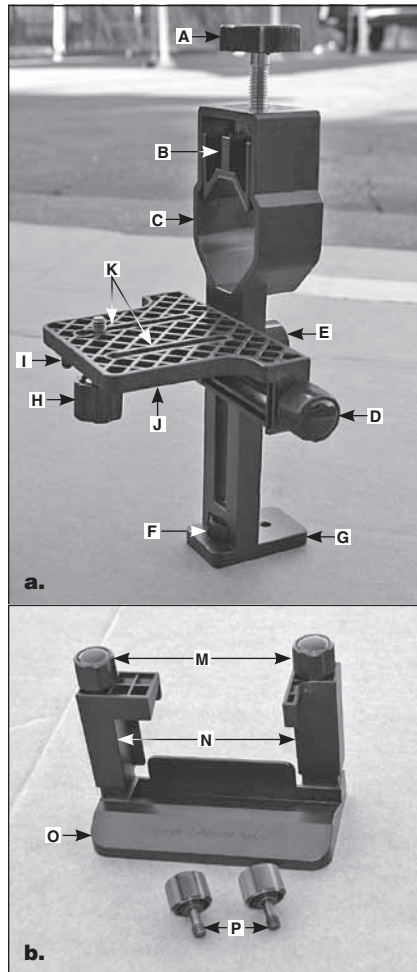

Figure 1. a) Parts of the SteadyPix Pro main unit. **b)** Parts of the universal smartphone bracket.

1. Raise the adjustable eyepiece clamp plate (B) as far as it will go by rotating the clamp adjusting knob (A) counterclockwise.
2. Insert the telescope’s eyepiece into the eyepiece holding clamp (C) and tighten the adjusting knob (A) until the grip on the eyepiece housing is firm.
3. Mount your digital camera on the camera platform (J) by threading the camera mounting bolt (H) into the $\frac{1}{4}$ "-20 socket on the bottom of the camera. Thread it in all the way, then back it off a turn or so. Now rotate the camera lock knob (I) clockwise to tightly hold the camera.
4. Turn the platform lock knob (E) counterclockwise to release the horizontal and vertical adjustment knobs (D and F). Now align the camera lens with the telescope eyepiece by adjusting the horizontal adjustment knob (D) and vertical adjustment knob (F) either clockwise or counterclockwise as needed. The lock the platform in place by tightening the platform lock knob (E).

Before powering your camera on in the next step, loosen the camera lock knob (I) and move the camera back on the platform along the platform slot (K) as far as it will go. Because with many digital cameras the lens expands outward when the power is turned on, setting the camera back from the telescope eyepiece will reduce the possibility that the lens will contact the eyepiece, causing damage to either or both of them.

5. Now turn on your camera and look at its LCD display. Move the camera forward – toward the eyepiece until the LCD screen shows a full image. You may also need to make small adjustments to the horizontal and vertical positioning of the camera using the adjustment knobs E and F. Also, make sure the eyepiece lens and the camera lens are parallel. Then tighten the camera lock knob (I) to fix the camera in the correctly aligned position.

If vignetting occurs; that is, if you see a dark circle around the image on the LCD screen, as in **Figure 2**, the camera lens may be too far away from the lens of the telescope eyepiece. In that case, loosen the camera lock knob (I) and carefully move the camera closer to the eyepiece until the



Figure 2. Camera position relative to the telescope eyepiece should be adjusted until the image covers as much of the LCD screen as possible.



Figure 3. The SteadyPix Pro with camera attached is shown mounted on an Orion SpaceProbe 3 reflector telescope.

vignetting is gone, if possible, then retighten the lock knob. Take care not to let the camera lens contact the eyepiece! Note that with some eyepiece and camera combinations, it may not be possible to eliminate vignetting entirely.

- Place the eyepiece (with SteadyPix Pro attached) back in the telescope's focuser (if the eyepiece was removed to install in the SteadyPix Pro) and secure it with the locking thumbscrew(s) (**Figure 3**). Now you're ready to aim, focus, and shoot!

TIPS:

- Before attaching the SteadyPix Pro with camera attached to the telescope, focus the object you want to photograph in the telescope eyepiece using the telescope's focuser. You may still have to tweak the focus a bit once the SteadyPix and camera are installed, but at least you'll be close to the focus point.

- We recommend using the camera's self-timer setting to take your picture, as this will allow a few seconds for any camera shaking caused by pressing the shutter button to settle down before the exposure begins. If the camera is shaking during the exposure the resulting image will be blurry. Many smartphone camera apps also have a self-timer feature.

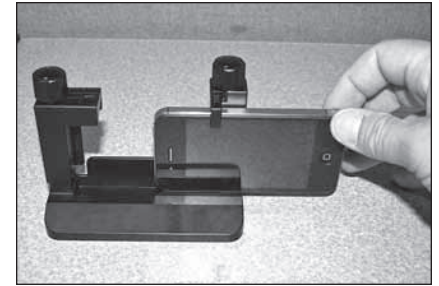

Figure 4. Slide your smartphone from right to left into the bracket.

For Smartphones

The smartphone bracket included with the SteadyPix Pro is compatible with phones measuring up to 3.15" (~80mm) in width and any length.

- Rotate the smartphone bracket post adjustment knobs (M) counterclockwise to raise the bracket posts (N) as needed to fit the width of your particular smartphone.
- Slide your smartphone into the bracket (O) from the right side as shown in **Figure 4**, with the phone's LCD screen facing toward you. Make sure that the phone's camera lens is not blocked by the bracket. Then tighten the post adjustment knobs (M) to lock the smartphone in place.
- Mount the smartphone bracket on the SteadyPix Pro camera platform using the camera mounting bolt (H) and camera lock knob (I) and one bracket attachment knob (P) into the two left-most holes in the base of the smartphone bracket (O) (**Figure 5**). (Depending on where your phone's camera lens is located, you may need to use the two right-most holes.)

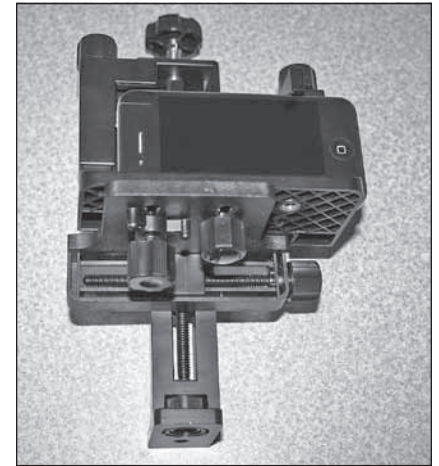

Figure 5. Attach the smartphone bracket to the SteadyPix camera platform.

4. Position the smartphone's camera lens approximately in the center of the eyepiece holding clamp (C) (**Figure 6**).
5. Center the smartphone's camera lens about a quarter inch back from the telescope eyepiece using the horizontal and vertical fine-adjustment knobs (D and F) and by moving the phone on the platform slots (K) as needed by slightly loosening the two attachment knobs (H/I and P). Ensure that the eyepiece lens and the phone's camera lens are parallel. When done, tighten the platform lock knob (E).
6. Turn on the smartphone and its camera. Make any horizontal, vertical, or front-to-back adjustments to the camera position until the LCD displays the largest image. Then tighten the lock knobs to fix the camera in that position (**Figure 7**).

Now you're ready to mount the assembly on the telescope and start shooting pictures.

Mounting the SteadyPix Pro on a Tripod

The SteadyPix Pro can be mounted on any camera tripod equipped with a 1/4"-20 post. This is useful when photographing through a small monocular, where the weight of the monocular can be supported solely by the eyepiece clamp of the SteadyPix Pro, while the heavier SteadyPix Pro is attached to the tripod (see **Figure 8**). Attach the SteadyPix Pro by threading the tripod's 1/4"-20 post into the 1/4"-20 socket (G).

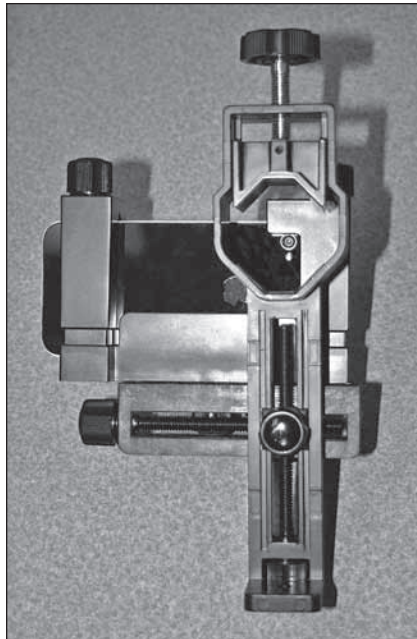

Figure 6. Center the smartphone's camera lens in the eyepiece holder clamp.

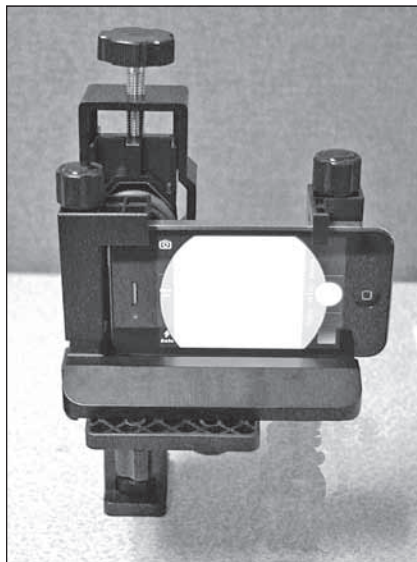

Figure 7. A smartphone is aligned in the SteadyPix Pro and ready to mount on the telescope.

Mounting the Smartphone Bracket on a Tripod

Mounting the smartphone bracket itself on a standard-size or mini tripod can be useful for taking family or group portraits (where you want to be in the picture too), self-portraits, or just wide-field terrestrial shots with your smartphone on a steady platform.

Just thread the tripod's 1/4"-20 post into the center socket on the bottom of the smartphone bracket (**Figure 9**).

What to Photograph with the SteadyPix Pro

Now that you have set up the SteadyPix Pro with your camera or smartphone and telescope or spotting scope, the only question remaining is "What can I photograph?" We have a few suggestions for you:

Terrestrial Photography

With literally millions of objects to photograph on earth, there are only a few tips we can give for using the SteadyPix Pro for terrestrial photography. One is to consider using a telescope with an Alt/Az (short for altitude/azimuth) mount on a sturdy tripod. An Alt/Az mount will allow simple up/down, left/right motions of the telescope so that you can easily adjust and aim the camera. Equatorial mounts (mounts designed to track the movement of stars in the sky) are not recommended, as they will be needlessly heavy due to the counterweight, and their ability to track celestial objects is of no use when photographing an object like a bird's nest. In fact it will likely get in the way.

Remember that objects viewed through certain types of telescopes will be oriented backwards, upside-down, or both so some telescopes may not be suitable for terrestrial photography.



Figure 8. The SteadyPix Pro is shown attached to a photo tripod via the 1/4"-20 socket in the SteadyPix's foot. A monocular is held in the eyepiece clamp.

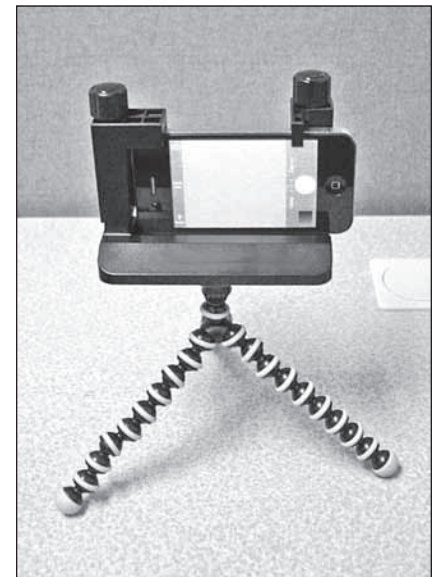

Figure 9. The smartphone bracket can be attached directly to a photo tripod's 1/4"-20 post.

The Moon

The Moon is one of the easiest and most interesting targets to photograph. With its rocky, cratered surface there is a wealth of detail to be photographed with your camera and SteadyPix Pro. You will be able to take beautiful images of the whole Moon or close-ups that showcase the craters, mountains, or maria. Single snapshots work well and multiple shots can be digitally stacked later in a program such as Registax to increase the signal-to-noise ratio and dynamic range of the image. Also, you can take video and then stack a series of the sharpest individual video frames. The Moon is a very large target, so at higher magnifications you may only get a part of the surface in each picture. Use eyepieces that provide low powers (50x and below should work with most telescopes) if you wish to have the entire surface of the Moon in your field of view.

Photographing the full Moon can be difficult since sunlight is falling directly on the lunar surface, producing no shadows, so details will be harder to see. Photographing the Moon when it is in one of its partial phases is preferable, as the angle of the Sun causes shadows highlighting the surface relief. You might also want to use an optional Moon filter that threads onto the bottom of the eyepiece to bring out more subtle features on the lunar surface, even during a full Moon.

The Sun

Photographing our nearest star, the Sun, is always interesting, but it must be done with caution. ***You must use a properly fitted solar filter covering the front opening of the telescope, or serious, instantaneous eye damage could occur with even a momentary glimpse of the Sun!*** The intense radiation emitted by the Sun could also damage your camera. Furthermore, if the scope has a finder scope attached, its lens should be covered with aluminum foil or a lens cap to prevent damage to your eyes or to the finder scope itself from excessive heat buildup.

With a proper solar filter installed on the telescope, you will be able to photograph sunspots on the Sun's surface and record their changing size, shapes, coloration, and patterns over time.

If you have a tracking mount, be sure to set the tracking rate to "Solar" to keep the Sun's disk in the eyepiece field of view.

The Bright Planets

Next to the Sun and the Moon, the planets Mars, Venus, Jupiter, and Saturn are the brightest objects in the sky and make excellent targets for afocal photography with the SteadyPix Pro. Keep in mind that the planets don't stay still like the stars, so to find them you should refer to In the Sky This Month at our website (OrionTelescopes.com), or to charts published monthly in Astronomy, Sky & Telescope, or other astronomy magazines.

To get the right amount of detail on the planets, eyepieces that give high powers (at least 75x or more) should be used when using the SteadyPix Pro. Low powers will make it easier to find the planets, but they will not bring out any significant details on the planets. High magnifications must be used to get images of the famous details of the planets, such as the rings of Saturn or bands on Jupiter's surface. Try using a 2x Barlow lens to boost the magnification of the eyepiece.

You might also consider using colored planetary filters that thread onto the bottom of the eyepiece (just like the Moon filter). These colored filters bring out subtle details of the planets by filtering out various colors that reduce detail. Orion has several sets of colored filters available. Visit our website, OrionTelescopes.com, for more information on colored planetary filters.

Deep-Sky Objects

It is very difficult, though not impossible, to shoot deep-sky objects – star clusters, nebulas, and galaxies – afocally with a point-and-shoot digital camera. That's because most of them are extremely faint. Deep-sky objects usually require use of a tracking mount and exposures of several seconds or more, which isn't always possible with typical point-and-shoot cameras. Some smartphone apps do have the ability to integrate a number of images into a final "long-exposure" image, allowing capture of brighter deep-sky objects. Try experimenting with shooting bright deep-sky objects with the equipment you have and see what kind of results you can obtain.

Specifications

SteadyPix Pro (Main Unit)

Size	195mm x 115mm x 105mm
Weight	12.4 oz. (350g)
Material	Aluminum, plastic
Eyepiece size compatibility	28mm – 45mm dia. (1.11"-1.77")
Platform load	4.5 lbs. (2.0kg) max.
Mounting	¼"-20 socket on foot

Smartphone Bracket

Size (min)	120mm x 60mm x 88mm
Weight	5.1 oz. (144g)
Material	Plastic
Max phone size	80mm width, any length
Mounting	¼"-20 sockets on bottom (x3)

WARNING: *Never look directly at the Sun with the naked eye or with a telescope – unless you have a proper solar filter installed over the front of the telescope! Otherwise, permanent, irreversible eye damage may result.*

One-Year Limited Warranty

This Orion product is warranted against defects in materials or workmanship for a period of one year from the date of purchase. This warranty is for the benefit of the original retail purchaser only. During this warranty period Orion Telescopes & Binoculars will repair or replace, at Orion's option, any warranted instrument that proves to be defective, provided it is returned postage paid. Proof of purchase (such as a copy of the original receipt) is required. This warranty is only valid in the country of purchase.

This warranty does not apply if, in Orion's judgment, the instrument has been abused, mishandled, or modified, nor does it apply to normal wear and tear. This warranty gives you specific legal rights. It is not intended to remove or restrict your other legal rights under applicable local consumer law; your state or national statutory consumer rights governing the sale of consumer goods remain fully applicable.

For further warranty information, please visit www.OrionTelescopes.com/warranty.

OrionTelescopes.com
89 Hangar Way, Watsonville, CA 95076
Customer Support Help Line (800) 676-1343

© 2013 Orion Telescopes & Binoculars